

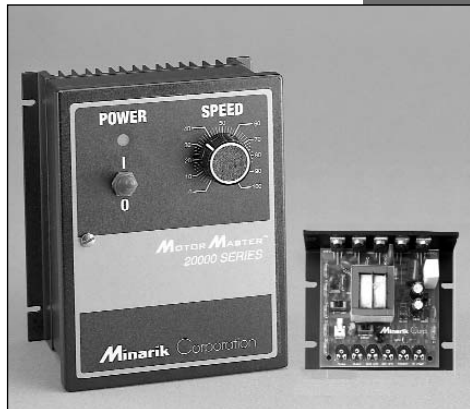

MM23000 Series



User's Manual

SCR, Adjustable Speed Drives
for DC Brush Motors

Copyright © 2002 by
Minarik Corporation

All rights reserved. No part of this manual may be reproduced or transmitted in any form without written permission from Minarik Corporation. The information and technical data in this manual are subject to change without notice. Minarik Corporation and its Divisions make no warranty of any kind with respect to this material, including, but not limited to, the implied warranties of its merchantability and fitness for a given purpose. Minarik Corporation and its Divisions assume no responsibility for any errors that may appear in this manual and make no commitment to update or to keep current the information in this manual. MVD032202

Printed in the United States of America.

Safety Warnings



- This symbol  denotes an important safety tip or warning. **Please read these instructions carefully** before performing any of the procedures contained in this manual.
- **DO NOT INSTALL, REMOVE, OR REWIRE THIS EQUIPMENT WITH POWER APPLIED.** Have a qualified electrical technician install, adjust and service this equipment. Follow the National Electrical Code and all other applicable electrical and safety codes, including the provisions of the Occupational Safety and Health Act (OSHA), when installing equipment.
- Reduce the chance of an electrical fire, shock, or explosion by proper grounding, over-current protection, thermal protection, and enclosure. Follow sound maintenance procedures.



It is possible for a drive to run at full speed as a result of a component failure. Minarik strongly recommends the installation of a master switch in the main power input to stop the drive in an emergency.

Circuit potentials are at 115 VAC or 230 VAC above earth ground. Avoid direct contact with the printed circuit board or with circuit elements to prevent the risk of serious injury or fatality. Use a non-metallic screwdriver for adjusting the calibration trimpots. Use approved personal protective equipment and insulated tools if working on this drive with power applied.

Contents

Safety Warnings	i
Specifications	1
Specifications (Continued)	2
Suffix Definitions	2
Dimensions	3
Installation	11
Chassis drives	11
Mounting	11
Wiring	12
Shielding guidelines	13
Heat sinking	14
Quick-disconnect terminal block (C-Q drives only)	15
Speed adjust potentiometer	16
Chassis drive connections	17
Power, fuse and motor connections	17
Voltage follower	23
Cased drives	24
Mounting (NEMA 1 enclosures)	24
Mounting (NEMA 4X and NEMA 12 enclosures)	25
Heat sinking	26
Line fusing	26
Connections	27
Current limit LED (C models only)	30
Meter header block (cased C models only)	30
MM23001C-Q, MM23071, and MM23072 diagnostic LEDs	31
Operation	32
Before applying power	32
Voltage select switches	33
Input voltage select (SW501)	33
Armature voltage select (SW502)	33
Startup	34
MM23001, MM23011, MM23071, and MM23072	34

MM23101, MM23111, MM23401, and MM23411	34
MM23201 and MM23211	35
MM23501	36
Starting and stopping methods	37
Line starting and line stopping	37
Inhibit terminals	38
Decelerating to minimum speed	39
Dynamic braking	40
Calibration	42
MINIMUM SPEED (MIN SPD)	43
MAXIMUM SPEED (MAX SPD)	43
TORQUE	44
IR COMPENSATION (IR COMP)	45
ACCELERATION (ACCEL)	47
DECELERATION (DECEL)	48
Application Notes	49
Multiple fixed speeds	49
Adjustable speeds using potentiometers in series	50
Independent adjustable speeds	51
RUN/JOG switch	52
RUN/JOG switch option #1	52
RUN/JOG switch option #2	53
Leader-follower application	54
Single speed potentiometer control of multiple drives	55
Reversing	56
Reversing with a DIGI-LOK controller	57
Troubleshooting	58
Before troubleshooting	58
Replacement Parts	66
CE Compliance	68
Line filters	69
Armature filters	70
Unconditional Warranty	.inside back cover

Illustrations

Figure 1. MM23001 and MM23011 Dimensions	3
Figure 2. MM23001C-Q and MM23011C-Q Dimensions	4
Figure 3. MM23101 and MM23111 Dimensions	5
Figure 4. MM23201 and MM23211 Dimensions	6
Figure 5. MM23401 and MM23411 Dimensions	7
Figure 6. MM23501 Dimensions	8
Figure 7. MM23071 and MM23072 Dimensions	9
Figure 8. Heat Sink Dimensions	10
Figure 9. Quick-Disconnect Terminal Block	15
Figure 10. Speed Adjust Potentiometer	16
Figure 11. Chassis Drive Connections	21
Figure 12. MM23201C-Q and MM23011C-Q Connections	22
Figure 13. Voltage Follower Connections	23
Figure 14. Cased Drive Connections	29
Figure 15. Voltage Switches	33
Figure 16. INHIBIT Terminals	38
Figure 17. Run/Decelerate to Minimum Speed Switch	39
Figure 18. Dynamic Brake Connection	41
Figure 19. Recommended Torque and IR COMP Settings	46
Figure 20. Multiple Fixed Speeds	49
Figure 21. Adjustable Fixed Speeds Using Potentiometers in Series	50
Figure 22. Independent Adjustable Speeds	51

Figure 23. RUN/JOG Switch Connection to Inhibit Plug (Option #1)	.52
Figure 24. RUN/JOG Switch Connection to Speed Adjust Potentiometer (Option #2)	.53
Figure 25. Leader-Follower Application	.54
Figure 26. Single Speed Potentiometer Control of Multiple Drives	.55
Figure 27. Reversing Circuit Connection	.56
Figure 28. Reversing with a DLC600	.57
Figure 29. MM23000 Series Block Diagram	.62
Figure 30. MM23101, MM23111, MM23401 and MM23411 Terminal Block Connections	.63
Figure 31. MM23201 and MM23211 Terminal Block Connections	.64
Figure 32. MM23501 Terminal Block Connections	.65

Tables

Table 1. Recommended Line Fuse Sizes	19
Table 2. Field Output Connections	20
Table 3. Field Output Connections	28
Table 4. Minimum Recommended Dynamic Brake Resistor Values ..	41
Table 5. Replacement Parts	66
Table 6. Corcom® Filters	69
Table 7. Minarik Filters	70

Specifications

Model	Max. Armature Current (Amps DC)	HP Range with 115 VAC Applied	HP Range with 230 VAC Applied	Style
MM23011	1.5	1/20–1/8	1/10–1/4	Chassis
MM23111				NEMA 1
MM23211				NEMA 1
MM23411				NEMA 4/4X/ 12
MM23072				Chassis
MM23001 †	5.0	1/8–1/2	1/4–1	Chassis
MM23101 ‡				NEMA 1
MM23201 ‡				NEMA 1
MM23071 †				Chassis
MM23401	10.0	1/8–1	1/4–2	NEMA 4/4X/12
MM23501				NEMA 4/4X/12

† Double maximum armature current and horsepower when drive is mounted on heat sink part number 223-0159.

‡ Double maximum armature current and horsepower when drive is mounted on heat sink part number 223-0174.

AC Line Voltage	115 VAC or 230 VAC \pm 10%, 50/60 Hz, single phase		
Armature Voltage (115 VAC Input)	0–90 VDC		
Armature Voltage (230 VAC Input)	0–180 VDC		
Form Factor	1.37 at base speed		
Field Voltage (115 VAC Input)	50 VDC (F1 to L1); 100 VDC (F1 to F2)		
Field Voltage (230 VAC Input)	100 VDC (F1 to L1); 200 VDC (F1 to F2)		
Max. Field Current	1 ADC		
Accel. Time Range:			
for 0–90 VDC Armature Voltage	0.5–11 seconds		
for 0–180 VDC Armature Voltage	0.5–22 seconds		
Decel. Time Range:			
for 0-90 VDC Armature Voltage	coast to a stop–13 seconds		
for 0–180 VDC Armature Voltage	coast to a stop–25 seconds		
Analog Input Voltage Range (signal must be isolated; S1 to S2):			
for 0–90 VDC Armature Voltage	0–1.4 VDC		
for 0–180 VDC Armature Voltage	0–2.8 VDC		

Specifications (Continued)

Input Impedance (S1 to S2)	100K ohms
Load Regulation	1% base speed or better
Vibration	0.5G max (0–50 Hz) 0.1G max (>50 Hz)
Safety Certification	UL Listed Equipment, file # E132235 UL Overload Protection CSA Certified Component, file # LR41380 CE Certificate of Compliance
Ambient Temp. Range (chassis drive)	10°C–55°C
Ambient Temp. Range (cased drive)	10°C–40°C

Suffix Definitions

- A: Basic drive
- C: Basic drive with current limit LED
- C-Q: Basic drive with current limit LED, power LED, and quick-disconnect terminal block

Note:

- C suffix applies to all models except MM23071 and MM23072.
- MM23071A and MM23072A drives include a current limit and power LED; trimmer potentiometers (trimpots) are perpendicular to the PC board.

Dimensions

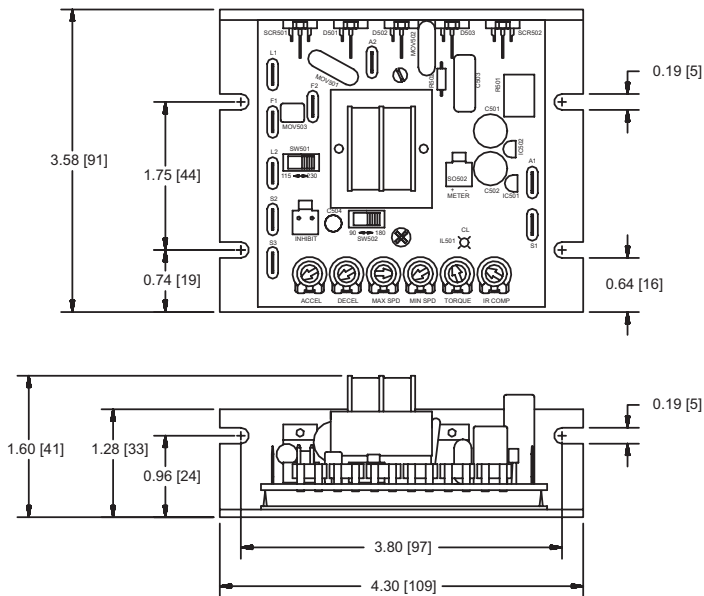

ALL DIMENSIONS IN INCHES [MILLIMETERS]

Figure 1. MM23001 and MM23011 Dimensions

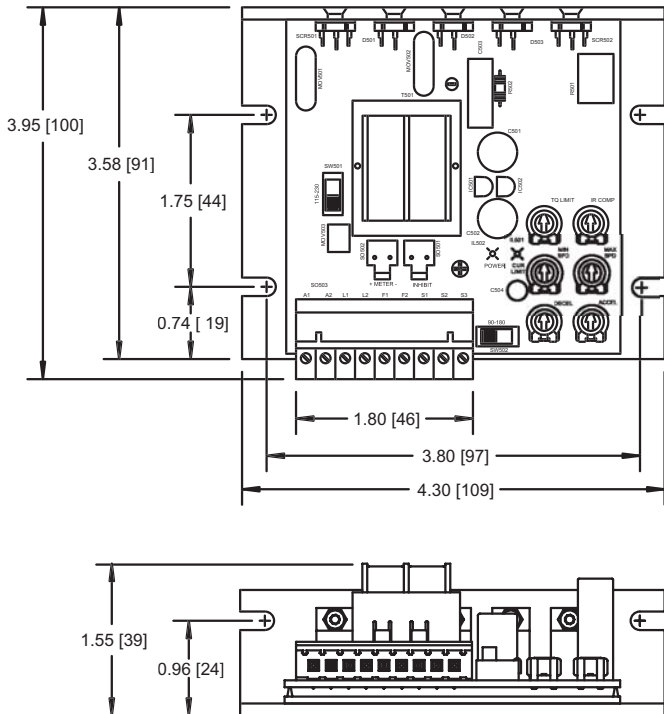

ALL DIMENSIONS IN INCHES [MILLIMETERS]

Figure 2. MM23001C-Q and MM23011C-Q Dimensions

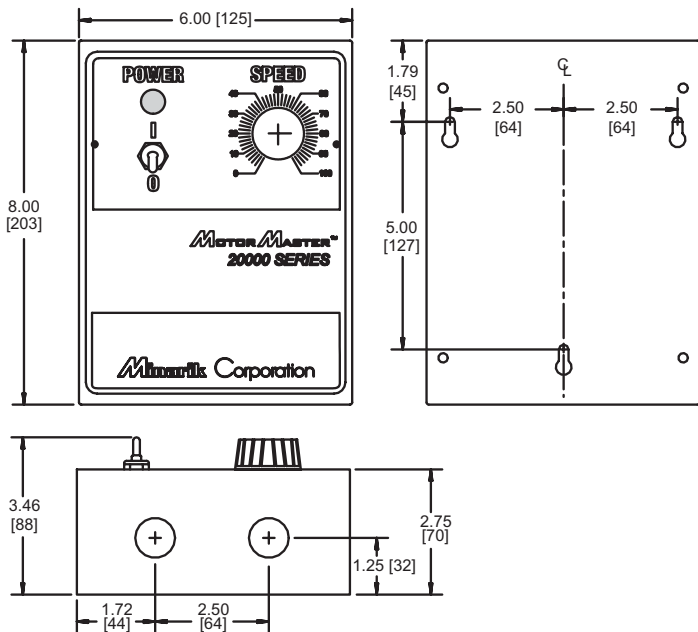

TWO 0.88 [22] CONDUIT HOLES

ALL DIMENSIONS IN INCHES [MILLIMETERS]

Figure 3. MM23101 and MM23111 Dimensions

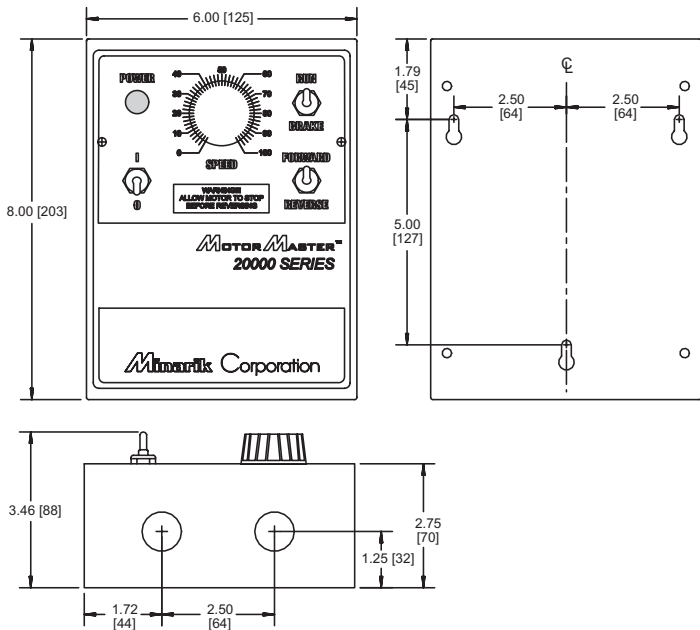

FOUR MOUNTING SLOTS 0.19 INCHES [5 MILLIMETERS] WIDE
 TWO 0.88 [22] KNOCKOUTS
 ALL DIMENSIONS IN INCHES [MILLIMETERS]

Figure 4. MM23201 and MM23211 Dimensions

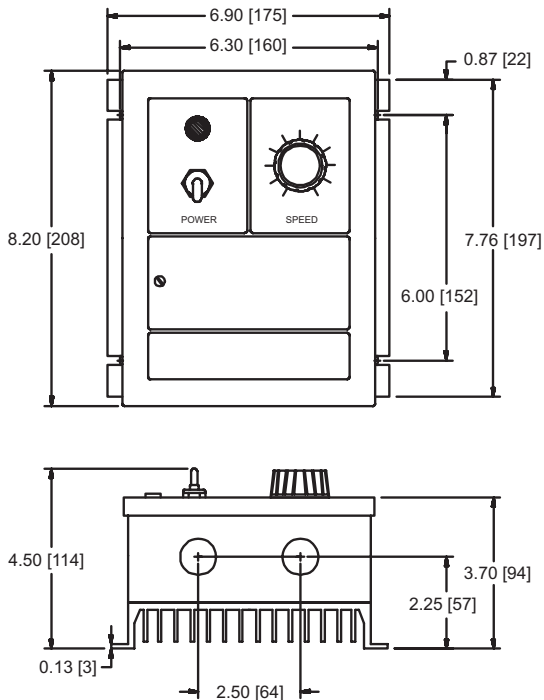

FOUR MOUNTING SLOTS 0.19 INCHES [5 MILLIMETERS] WIDE
TWO 0.88 [22] KNOCKOUTS
ALL DIMENSIONS IN INCHES [MILLIMETERS]

Figure 5. MM23401 and MM23411 Dimensions

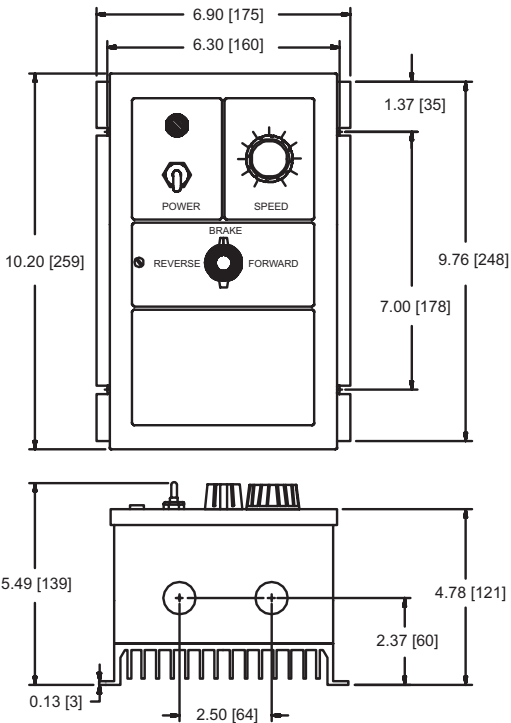

FOUR MOUNTING SLOTS 0.19 INCHES [5 MILLIMETERS] WIDE
TWO 0.88 [22] KNOCKOUTS
ALL DIMENSIONS IN INCHES [MILLIMETERS]

Figure 6. MM23501 Dimensions

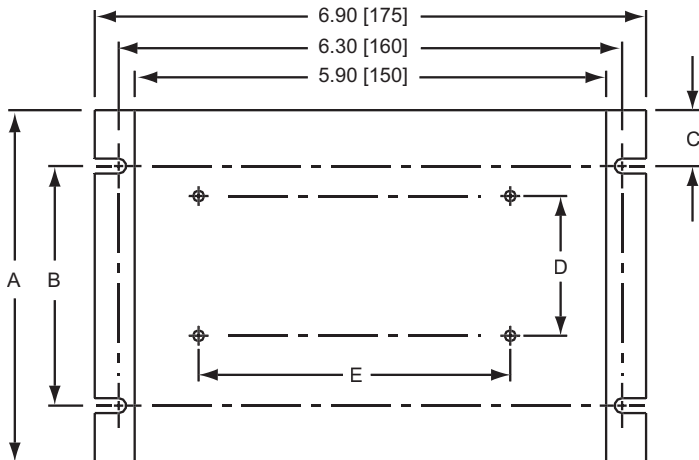

MOUNTING SLOTS 0.19 X 0.34 [5 X 9]
 ALL DIMENSIONS IN INCHES [MILLIMETERS]

PART NO.	DIM "A"	DIM "B"	DIM "C"	DIM "D"	DIM "E"
223-0159	4.40 [112]	3.00 [76]	0.7 [18]	1.75 [44]	3.90 [100]
223-0174	7.78 [198]	6.00 [152]	0.89 [23]	6.00 [152]	5.35 [136]

Heat sinks sold separately.

Figure 8. Heat Sink Dimensions

Installation



Warning

Do not install, rewire, or remove this control with input power applied. Doing so may cause fire or serious injury. Make sure you have read and understood the Safety Warnings on page i before attempting installation.

Chassis drives

Mounting

- Drive components are sensitive to electrostatic fields. Avoid contact with the circuit board directly. Hold drive by the chassis only.
- Protect the drive from dirt, moisture, and accidental contact.
- Provide sufficient room for access to the terminal block and calibration trimpots.
- Mount the drive away from other heat sources. Operate the drive within the specified ambient operating temperature range.
- Prevent loose connections by avoiding excessive vibration of the drive.
- Mount drive with its board in either a horizontal or vertical plane. Six 0.19 inch (5 mm) wide slots in the chassis accept #8 pan head screws. Fasten either the large base or the narrow flange of the chassis to the subplate.
- The chassis must be earth grounded. To ground the chassis, use a star washer beneath the head of at least one of the mounting screws to penetrate the anodized chassis surface and to reach bare metal.

Wiring

Warning

Do not install, remove, or rewire this equipment with power applied. Failure to heed this warning may result in fire, explosion, or serious injury.

Circuit potentials are at 115 or 230 VAC above ground. To prevent the risk of injury or fatality, avoid direct contact with the printed circuit board or with circuit elements.

Do not disconnect any of the motor leads from the drive unless power is removed or the drive is disabled. Opening any one motor lead may destroy the drive.

- Use 18-24 AWG wire for speed adjust potentiometer wiring. Use 14–16 AWG wire for AC line (L1, L2) and motor (A1 and A2) wiring.

Shielding guidelines



Warning

Under no circumstances should power and logic leads be bundled together. Induced voltage can cause unpredictable behavior in any electronic device, including motor controls.

As a general rule, Minarik recommends shielding of all conductors.

If it is not practical to shield power conductors, Minarik recommends shielding all logic-level leads. If shielding of logic leads is not practical, the user should twist all logic leads with themselves to minimize induced noise.

It may be necessary to earth ground the shielded cable. If noise is produced by devices other than the drive, ground the shield at the drive end. If noise is generated by a device on the drive, ground the shield at the end away from the drive. Do not ground both ends of the shield.

If the drive continues to pick up noise after grounding the shield, it may be necessary to add AC line filtering devices, or to mount the drive in a less noisy environment.

Logic wires from other input devices, such as motion controllers and PLL velocity controllers, must be separated from power lines in the same manner as the logic I/O on this drive.

Heat sinking

Models MM23001 and MM23071 require an additional heat sink when the continuous armature current is above 5 ADC. Use Minarik part number 223-0159. All other chassis drives have sufficient heat sinking in their basic configurations. Use a thermally conductive heat sink compound (such as Dow Corning[®] 340 Heat Sink Compound) between the drive chassis and heat sink surface for optimum heat transfer.

Quick-disconnect terminal block (C-Q drives only)

The quick-disconnect terminal block, found only on C-Q drives, is composed of a 9-pin header block and 9-screw terminal plug (Figure 9). To use the quick-disconnect terminal block:

1. Carefully pull terminal plug from header block.
2. With a small flat-head screwdriver, turn terminal plug screw counterclockwise to open wire clamp.
3. Insert stripped wire into the large opening in front of the plug.
4. Turn the terminal plug screw clockwise to clamp the wire.
5. Repeat steps 2–4 for each terminal until all connections are made. Make no connections to F1 and F2 if using a permanent magnet motor.
6. Insert plug into header until securely fastened.

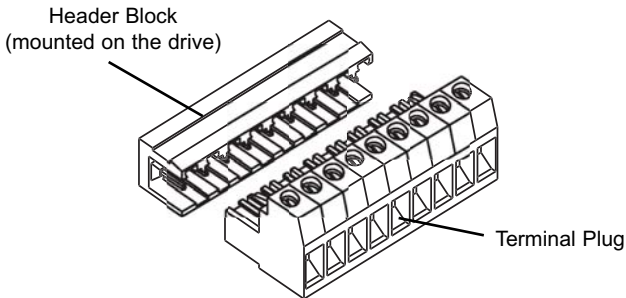

Figure 9. Quick-Disconnect Terminal Block

Speed adjust potentiometer

Warning

Be sure that the potentiometer tabs do not make contact with the potentiometer enclosure. Grounding the input will cause damage to the drive.

Mount the speed adjust potentiometer through a 0.38 in. (10 mm) hole with the hardware provided (Figure 10). Install the circular insulating disk between the panel and the 10K ohm speed adjust potentiometer.

Twist the speed adjust potentiometer wire to avoid picking up unwanted electrical noise. If speed adjust potentiometer wires are longer than 18 in. (457 mm), use shielded cable. Keep speed adjust potentiometer wires separate from power leads (L1, L2, A1, A2).

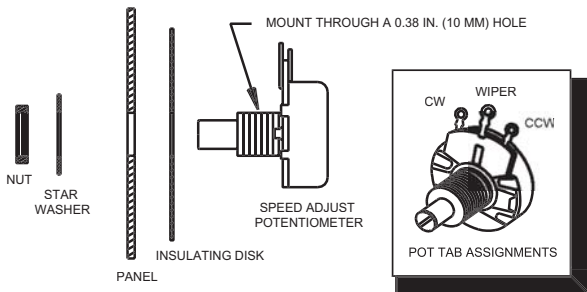

Figure 10. Speed Adjust Potentiometer

Chassis drive connections



Warning

Do not connect this equipment with power applied. Failure to heed this directive may result in fire or serious injury.

Minarik strongly recommends the installation of a master power switch in the voltage input line, as shown in Figure 11 (page 21). The switch contacts should be rated at a minimum of 200% of motor nameplate current and 250 volts.

Power, fuse and motor connections

Connect the power input leads, an external line fuse and a DC motor to TB501 on the drive's printed circuit board (PCB) as shown in Figure 11, page 21.

Motor

Minarik drives supply motor armature voltage from A1 and A2 terminals. It is assumed throughout this manual that, when A1 is positive with respect to A2, the motor will rotate clockwise (CW) while looking at the output shaft protruding from the front of the motor. If this is opposite of the desired rotation, simply reverse the wiring of A1 and A2 with each other.

Connect a DC motor to PCB terminals A1 and A2 as shown in Figure 11, page 21. Ensure that the motor voltage rating is consistent with the drive's output voltage.

Power input

Connect the AC line power leads to terminals L1 and L2, or to a single-throw, double-pole master power switch (recommended). The switch should be rated at a minimum of 250 volts and 200% of motor current. Refer to Figure 11, page 21.

Line fuse

Minarik drives require an external fuse for protection. Use fast acting fuses rated for 250 VAC or higher, and approximately 150% of the maximum armature current. Fuse only the HOT leg of the AC line that connects to L1 and leave L2 unfused when the AC line voltage is 115 VAC. Table 1 (page 19) lists the recommended line fuse sizes.

Wire an external line fuse between the stop switch (if installed) and the L1 terminal on terminal board TB501. An additional line fuse should be installed on L2 if the input voltage is 230VAC. The line fuse(s) should be rated at 250 volts and 150 - 200% of maximum motor nameplate current.

Table 1. Recommended Line Fuse Sizes

90 VDC Motor Horsepower	180 VDC Horsepower	Max. DC Armature Current (amps)	AC Line Fuse Size (amps)
1/20	1/10	0.5	1
1/15	1/8	0.8	1.5
1/8	1/4	1.5	3
1/6	1/3	1.7	3
1/4	1/2	2.5	5
1/3	3/4	3.5	8
1/2	1	5.0	10
3/4	1 1/2	7.5	15
1	2	10	15

Minarik Corporation offers two fuse kits: part number 050-0066 (1-5A Fuse Kit) and 050-0071 (5-15A Fuse Kit).

Field output connections

Warning

The field output is for shunt wound motors only. Do not make any connections to F1 and F2 when using a permanent magnet motor.

See Table 2 for field output connections. Use 18 AWG wire to connect the field output to a shunt wound motor.

Table 2. Field Output Connections

Line Voltage (VAC)	Approximate Field Voltage (VDC)	Connect Motor Field To
115	50	F1 and L1
115	100	F1 and F2
230	100	F1 and L1
230	200	F1 and F2

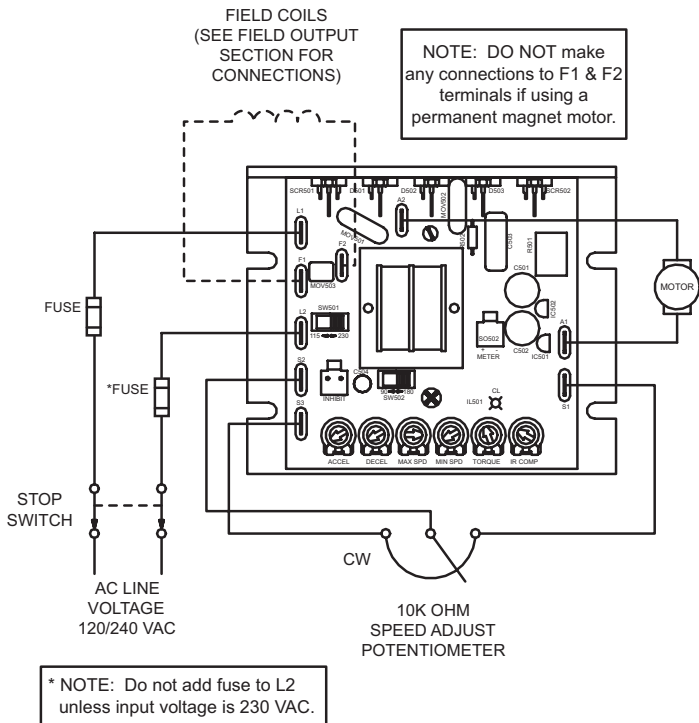

Figure 11. Chassis Drive Connections

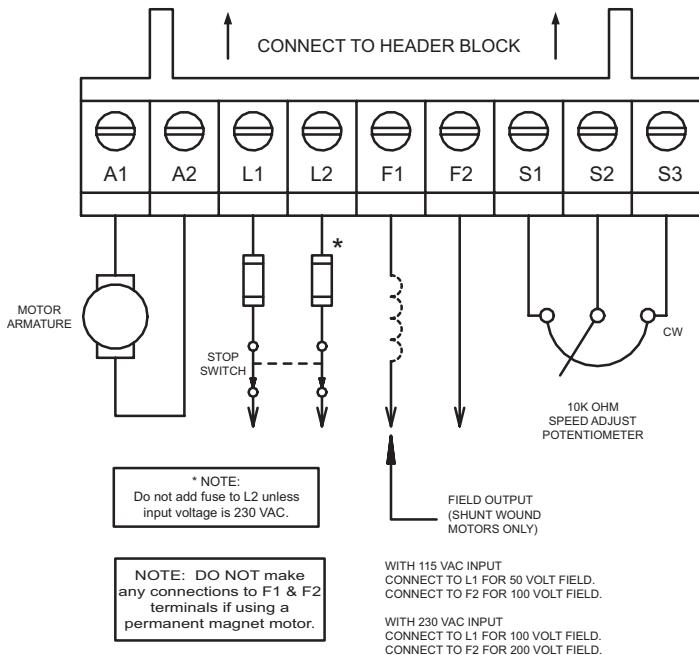

Figure 12. MM23001C-Q and MM23011C-Q Connections

Voltage follower

Instead of using a speed adjust potentiometer, the drive may be wired to follow an analog input voltage signal that is isolated from earth ground (Figure 13). Connect the signal input (+) to S2. Connect the signal common (–) to S1. Make no connection to S3. A potentiometer can be used to scale the analog input voltage. An interface device, such as Minarik model PCM4, may be used to scale and isolate an analog input voltage.

With either 115 VAC or 230 VAC line voltage, an analog input voltage range of approximately 0–1.4 VDC is required to produce an armature voltage range of 0–90 VDC. With 230 VAC line voltage, an analog input voltage range of approximately 0–2.8 VDC is required to produce an armature voltage range of 0–180 VDC.

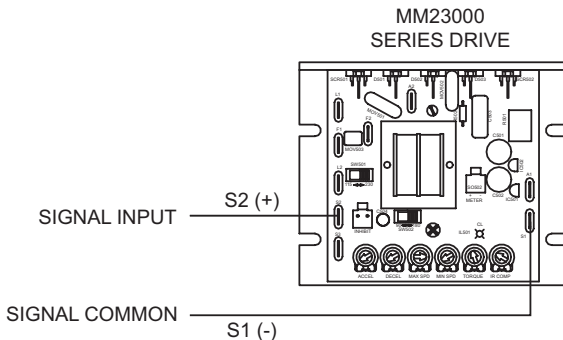

Figure 13. Voltage Follower Connections

Cased drives

Warning

Do not install, rewire, or remove this control with input power applied. Doing so may cause fire or serious injury. Make sure you have read and understood the Safety Warnings on page i before attempting installation.

Mounting (NEMA 1 enclosures)

NEMA 1 cased drives come with two 0.88 inch (22 mm) conduit holes at the bottom of the case. The units may be vertically wall mounted or horizontally bench mounted using the three keyholes on the back of the case.

1. For access to the keyholes and the terminal strip, remove the two screws from the front of the case by turning them counterclockwise. Grasp the front cover and lift it straight out.
2. Install the mounting screws in the three keyholes.
3. Install conduit hardware through the conduit holes at the bottom of the case. Connect external wiring to the terminal block.
4. Reinstall the front cover. Avoid pinching any wires between the front cover and the case.
5. Replace the two screws to the front cover. Turn the screws clockwise to tighten.
6. Set the POWER switch to the OFF position before applying the AC line voltage.

Mounting (NEMA 4X and NEMA 12 enclosures)

NEMA 4X and NEMA 12 cased drives come with two 0.88 inch (22 mm) conduit knockout holes at the bottom of the case. The units may be vertically wall mounted using the four 0.19 inch (5 mm) slotted holes on the attached heat sink. For motor loads less than 5 ADC, the drive may be bench mounted horizontally, or operated without mounting.

1. Install the mounting screws.
2. For access to the terminal strip, turn the slotted screw on the front cover counterclockwise until it is free from the case. The right side of the cover is hinged to the case. Pull the slotted screw to open the case.
3. Carefully remove the conduit knockouts by tapping them into the case and twisting them off with pliers.
4. Install conduit hardware through the 0.88 inch (22 mm) knockout holes. Connect external wiring to the terminal block.
5. Grasp the slotted screw and tilt the front cover back into place. Avoid pinching any wires between the front cover and the case.
6. Turn the slotted screw clockwise until tight to secure the front cover.
7. Set the POWER switch to the OFF position before applying the AC line voltage.

Heat sinking

Models MM23101 and MM23201 require additional heat sinking when the continuous armature current is above 5 ADC. Use Minarik part number 223-0174. All other cased drives have sufficient heat sinking in their basic configurations. Use a thermally conductive heat sink compound (such as Dow Corning® 340 Heat Sink Compound) between the back of the drive case and heat sink surface for optimum heat transfer.

Line fusing

15 amp line fuses are preinstalled on the cased models MM23101, MM23201, MM23401, and MM23501. 3 amp line fuses are preinstalled on the cased models MM23111, MM23211, and MM23411.

If the horsepower rating of the motor being used is less than the maximum horsepower rating of the drive, the line fuse may have to be replaced with a lower rated one. Refer to the “Recommended Line Fuse Sizes” table on page 18 to install a lower rated fuse.

Connections



Warning

Do not connect this equipment with power applied.

Failure to heed this directive may result in fire or serious injury.

Minarik strongly recommends the installation of a master power switch in the voltage input line. The switch contacts should be rated at a minimum of 200% of motor nameplate current and 250 volts.

Power and motor connections

Connect the power input leads and a DC motor to TB501 as shown in Figure 14, page 29.

Motor

Minarik drives supply motor voltage from A1 and A2 terminals. It is assumed throughout this manual that, when A1 is positive with respect to A2, the motor will rotate clockwise (CW) while looking at the output shaft protruding from the front of the motor. If this is opposite of the desired rotation, simply reverse the wiring of A1 and A2 with each other.

Connect a DC motor to PCB terminals A1 and A2 as shown in Figure 14. Ensure that the motor voltage rating is consistent with the drive's output voltage.

Power input

Connect the AC line power leads to TB501 terminals L1 and L2, or to a double-throw, single-pole master power switch (recommended).

Field output connections

Warning

The field output is for shunt wound motors only. Do not make any connections to F1 and F2 when using a permanent magnet motor.

See Table 3 for field output connections. Use 18 AWG wire to connect the field output to a shunt wound motor.

Table 3. Field Output Connections

Line Voltage (VAC)	Approximate Field Voltage (VDC)	Connect Motor Field To
115	50	F1 and L1
115	100	F1 and F2
230	100	F1 and L1
230	200	F1 and F2

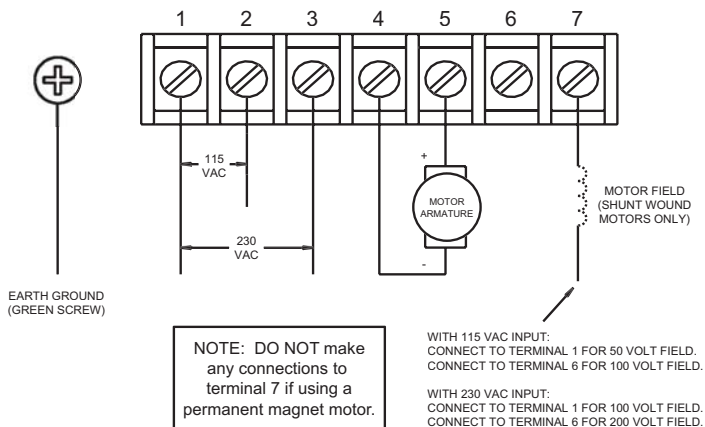
**Figure 14. Cased Drive Connections**

Current limit LED (**C models only**)

MM23000C series drives are equipped with a red current limit LED. The red current limit LED turns on whenever the drive reaches current limit and turns off whenever the drive is not in current limit (normal operation).

Meter header block (*cased C models only*)

To supply power to external devices, the *Meter* header block can supply an unregulated +9 VDC (5 mA) signal when the motor and the power supply of the drive are fully loaded. More current is available with less motor loading. *Meter* can supply an unregulated +15V (10 mA) signal in typical applications.

MM23001C-Q, MM23071, and MM23072 diagnostic LEDs

Models MM23001C-Q, MM23071, and MM23072 are equipped with two diagnostic LEDs:

Power (PWR): Lights whenever the AC line voltage is applied to the drive.

Current Limit (CURR LIMIT or CL): Lights whenever the drive reaches current limit.

Operation

Warning

Change voltage switch settings only when the drive is disconnected from AC line voltage. Make sure both switches are set to their correct position. If the switches are improperly set to a lower voltage position, the motor will not run at full voltage and may cause damage to the transformer. If the switches are improperly set to a higher voltage position, the motor will overspeed, which may cause motor damage, or result in bodily injury or loss of life.

Dangerous voltages exist on the drive when it is powered. BE ALERT. High voltages can cause serious or fatal injury. For your safety, use personal protective equipment (PPE) when operating this drive.

If the motor or drive does not perform as described, disconnect the AC line voltage immediately. Refer to the Troubleshooting section, page 57, for further assistance.

Before applying power

- Verify that no conductive material is present on the printed circuit board.
- Ensure that the voltage select switches are properly set.

Voltage select switches

Input voltage select (SW501)

Set the voltage switch SW501 to either 115V or 230V to match the AC line voltage. See Figure 15.

Armature voltage select (SW502)

Set the voltage switch SW502 to either 90V or 180V to match the maximum armature voltage. See Figure 15.

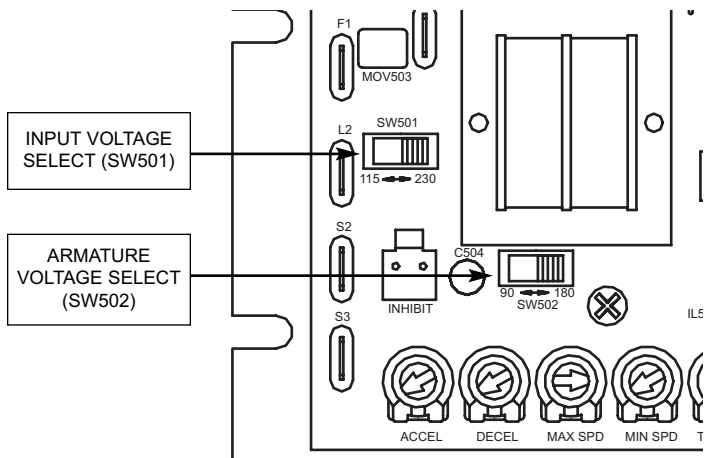

Figure 15. Voltage Switches

Startup

MM23001, MM23011, MM23071, and MM23072

1. Turn the speed adjust potentiometer full counterclockwise (CCW) or set the voltage signal to minimum.
2. Apply AC line voltage.
3. Slowly advance the speed adjust potentiometer clockwise (CW) or increase the voltage signal. The motor slowly accelerates as the potentiometer is turned CW. Continue until the desired speed is reached.
4. Remove AC line voltage from the drive to coast the motor to a stop.

MM23101, MM23111, MM23401, and MM23411

1. Set the speed adjust potentiometer to "0" (full CCW).
2. Apply AC line voltage.
3. Set the POWER switch to the ON position.
4. Slowly advance the speed adjust potentiometer clockwise (CW). The motor slowly accelerates as the potentiometer is turned CW. Continue until the desired speed is reached.
5. Set the POWER switch to the OFF position to coast the motor to a stop.

MM23201 and MM23211



Warning

Do not change the FORWARD / REVERSE switch while the motor is running. The motor must come to a complete stop before reversing. Changing motor direction before allowing the motor to completely stop will cause excessively high current to flow in the armature circuit, and will damage the drive and/or motor.

1. Set the RUN/BRAKE switch to the BRAKE position.
2. Set the speed adjust potentiometer to "0" (full CCW).
3. Apply AC line voltage.
4. Set the POWER switch to the ON position.
5. Set the FORWARD/REVERSE switch to the desired direction of rotation.
6. Set the RUN/BRAKE switch to the RUN position.
7. Slowly advance the speed adjust potentiometer clockwise (CW).
The motor slowly accelerates as the potentiometer is turned CW.
Continue until the desired speed is reached.
8. To reverse direction:
 - a. Set the RUN/BRAKE switch to the BRAKE position.
 - b. Set the FORWARD/REVERSE switch to the desired direction of rotation.
 - c. Set the RUN/BRAKE switch to the RUN position.
9. To brake the motor, set the RUN/BRAKE switch to the BRAKE position. To coast the motor to a stop, set the POWER switch to the OFF position.

MM23501**Warning**

The motor must come to a complete stop before reversing. Changing motor direction before allowing the motor to completely stop will cause excessively high current to flow in the armature circuit, and will damage the drive and/or motor.

1. Set the FORWARD/BRAKE/REVERSE switch to the BRAKE position.
2. Set the speed adjust potentiometer to "0" (full CCW).
3. Apply AC line voltage.
4. Set the POWER switch to the ON position.
5. Set the FORWARD/BRAKE/REVERSE switch to the desired direction of rotation.
7. Slowly advance the speed adjust potentiometer clockwise (CW). The motor slowly accelerates as the potentiometer is turned CW. Continue until the desired speed is reached.
8. To reverse direction:
 - a. Set the FORWARD/BRAKE/REVERSE switch to the BRAKE position.
 - b. After the motor comes to a complete stop, set the FORWARD/BRAKE/REVERSE switch to the desired direction of rotation.
9. To brake the motor, set the FORWARD/BRAKE/REVERSE switch to the BRAKE position. To coast the motor to a stop, set the POWER switch to the OFF position.

Starting and stopping methods



Warning

Decelerating to minimum speed, dynamic braking, or coasting to a stop is recommended for frequent starts and stops. Do not use any of these methods for emergency stopping. They may not stop a drive that is malfunctioning. Removing AC line power (both L1 and L2) is the only acceptable method for emergency stopping.

For this reason, **Minarik strongly recommends installing an emergency stop switch on both the L1 and L2 inputs** (see connection diagrams on pages 21 & 22).

Line starting and line stopping

Line starting and line stopping (applying and removing AC line voltage) is recommended for infrequent starting and stopping of a drive only. When AC line voltage is applied to the drive, the motor accelerates to the speed set by the speed adjust potentiometer or voltage reference signal. When AC line voltage is removed, the motor coasts to a stop.

Inhibit terminals

Short the INHIBIT terminals to coast the motor to minimum speed (see Figure 16 for INHIBIT terminal location). Open the INHIBIT terminals to accelerate the motor to set speed.

Twist inhibit wires and separate them from power-carrying wires or sources of electrical noise. Use shielded cable if the inhibit wires are longer than 18 inches (46 cm). If shielded cable is used, ground only one end of the shield to earth ground. Do not ground both ends of the shield.

Minarik Corporation offers two accessory plug harnesses for connecting to the INHIBIT terminals: part number 201-0024 [inhibit plug with 18 inches (46 cm) leads]; and part number 201-0079 [inhibit plug with 36 inches (91 cm) leads].

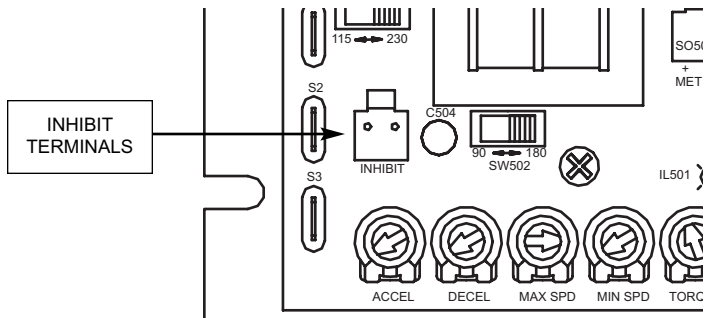

Figure 16. INHIBIT Terminals

Decelerating to minimum speed

The switch shown in Figure 16 may be used to decelerate a motor to a minimum speed. Closing the switch between S1 and S2 decelerates the motor from set speed to a minimum speed determined by the MIN SPD trimpot setting. If the MIN SPD trimpot is set full CCW, the motor decelerates to zero speed when the switch between S1 and S2 is closed. The DECEL trimpot setting determines the rate at which the drive decelerates. By opening the switch, the motor accelerates to set speed at a rate determined by the ACCEL trimpot setting.

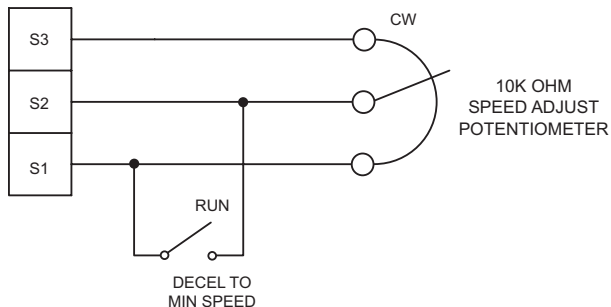

Figure 17. Run/Decelerate to Minimum Speed Switch

Dynamic braking

Warning

For frequent starts and stops, short the inhibit terminals, decelerate to a minimum speed, or apply a dynamic brake to the motor. Do not use any of these methods for emergency stopping. They may not stop a drive that is malfunctioning. Removing AC line power (both L1 and L2) is the only acceptable method for emergency stopping.

Frequent starting and stopping can produce high torque. This may cause damage to motors, especially gearmotors that are not properly sized for the application.

Dynamic braking may be used to rapidly stop a motor (Figure 18, page 41). For the RUN/BRAKE switch, use a two pole, two position switch rated for at least 125 VDC, 6 amps. For the dynamic brake resistor, use a 40 watt minimum, high power, wirewound resistor.

Sizing the dynamic brake resistor depends on load inertia, motor voltage, and braking time. Use a lower-value, higher-wattage dynamic brake resistor to stop a motor more rapidly. Refer to Table 4 (page 40) for recommended dynamic brake resistor sizes.

Note: Models MM23201, MM23211, and MM23501 incorporate dynamic braking in their designs.

Table 4. Minimum Recommended Dynamic Brake Resistor Values

Motor Armature Voltage	Dynamic Brake Resistor Value
90 VDC	15 ohms
180 VDC	30 ohms

For motors rated $\frac{1}{17}$ horsepower and lower, a brake resistor is not necessary since the armature resistance is high enough to stop the motor without demagnetization. Replace the dynamic brake with 12-gauge wire.

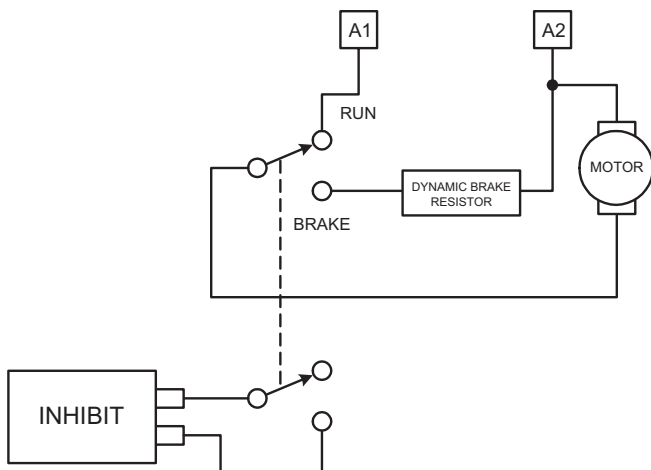

Figure 18. Dynamic Brake Connection

Calibration

Warning

Dangerous voltages exist on the drive when it is powered. When possible, disconnect the voltage input from the drive before adjusting the trimpots. If the trimpots must be adjusted with power applied, use insulated tools and the appropriate personal protection equipment. BE ALERT. High voltages can cause serious or fatal injury.

MM23000-series drives have user-adjustable trimpots. Each drive is factory calibrated to its maximum current rating. Readjust the calibration trimpot settings to accommodate lower current rated motors.

All adjustments increase with CW rotation, and decrease with CCW rotation. Use a non-metallic screwdriver for calibration. Each trimpot is identified on the printed circuit board.

MINIMUM SPEED (MIN SPD)

The MIN SPD trimpot establishes the motor speed obtained in response to the minimum input signal. It is factory set for zero speed.

To calibrate the MIN SPD pot, apply the minimum signal. Adjust the MIN SPD trimpot until the motor runs at the desired speed or is just at the threshold of rotation.

MAXIMUM SPEED (MAX SPD)

The MAX SPD setting determines the maximum motor speed when the speed adjust potentiometer, or voltage input signal is set for maximum forward speed. It is factory set for maximum rated motor speed.

To calibrate MAX SPD:

1. Set the MAX SPD trimpot full CCW.
2. Set the speed adjust potentiometer or voltage input signal for maximum forward speed.
3. Adjust MAX SPD until the desired maximum forward speed is reached.

Note: Check the MIN SPD and MAX SPD adjustments after recalibrating to verify that the motor runs at the desired minimum and maximum speed.

TORQUE

Warning

TORQUE should be set to 150% of motor nameplate current rating. Continuous operation beyond this rating may damage the motor. If you intend to operate beyond the rating, contact your Minarik representative for assistance.

The TORQUE setting determines the maximum torque for accelerating and driving the motor. To calibrate TORQUE, refer to the recommended TORQUE settings in Figure 19 (page 46) or us the following procedure:

1. With the power disconnected from the drive, connect a DC ammeter in series with the armature.
2. Set the TORQUE trimpot to minimum (full CCW).
3. Set the speed adjust potentiometer or voltage reference signal to maximum speed (full CW).
4. Carefully lock the motor armature. Be sure that the motor is firmly mounted.
5. Apply line power. The motor should be stopped.
6. Slowly adjust the TORQUE trimpot CW until the armature current is 150% of motor rated armature current.
7. Turn the speed adjust potentiometer CCW.
8. Remove line power.
9. Remove the stall from the motor.
10. Remove the ammeter in series with the motor armature if it is no longer needed.

IR COMPENSATION (IR COMP)

The IR COMP trimpot setting determines the degree to which motor speed is held constant as the motor load changes. It is factory set for optimum motor regulation.

Use the following procedure to recalibrate the IR COMP setting:





















1. Set the IR COMP trimpot to minimum (full CCW).
2. Rotate the speed adjust potentiometer until the motor runs at midspeed without load (for example, 900 RPM for an 1800 RPM motor). A handheld tachometer may be used to measure motor speed.
3. Load the motor armature to its full load armature current rating. The motor should slow down.
4. While keeping the load on the motor, rotate the IR COMP trimpot until the motor runs at the speed measured in step 2. If the motor oscillates (overcompensation), the IR COMP trimpot may be set too high (CW). Turn the IR COMP trimpot CCW to stabilize the motor.
5. Unload the motor.

See Figure 19, for recommended IR COMP settings.

MODELS MM23011, MM23111, MM23211, MM23072, and MM23411

		1/8 HP 90 VDC 1800 RPM 1.3 AMPS			1/4 HP 180 VDC 1800 RPM 1.4 AMPS
		1/15 HP 90 VDC 1800 RPM 0.77 AMPS			1/8 HP 180 VDC 1800 RPM 0.67 AMPS

MODELS MM23001, MM23071, MM23101, MM23201, MM23401, and MM23501

		1 HP 90 VDC 1750 RPM 10 AMPS			2 HP 180 VDC 1750 RPM 9.2 AMPS
		3/4 HP 90 VDC 1750 RPM 7.6 AMPS			1 1/2 HP 180 VDC 1800 RPM 7 AMPS
		1/2 HP 90 VDC 1750 RPM 5 AMPS			1 HP 180 VDC 1750 RPM 5 AMPS
		1/3 HP 90 VDC 1750 RPM 3.5 AMPS			3/4 HP 180 VDC 1750 RPM 3.8 AMPS
		1/4 HP 90 VDC 1750 RPM 2.7 AMPS			1/2 HP 180 VDC 1750 RPM 1.3 AMPS

**Figure 19. Recommended Torque and IR COMP Settings
(actual settings may vary with each application)**

ACCELERATION (ACCEL)

The ACCEL setting determines the time the motor takes to ramp to a higher speed. See Specifications on page 1 for approximate acceleration times. ACCEL is factory set for the fastest acceleration time (full CCW).

To set the acceleration time:

1. Set the speed adjust potentiometer full CCW. The motor should run at minimum speed.
2. Turn the speed adjust potentiometer full CW and measure the time it takes the motor to go from minimum to maximum speed.
3. If the time measured in step 2 is not the desired acceleration time, turn the ACCEL trimpot CW for a slower acceleration time, or CCW for a faster acceleration time. Repeat steps 1 through 3 until the acceleration time is correct.

DECELERATION (DECEL)

The DECEL setting determines the time the motor takes to ramp to a lower speed. See Specifications on page 1 for approximate deceleration times. DECEL is factory set for the fastest deceleration time (full CCW).

To set the deceleration time:

1. Set the speed adjust potentiometer full CW. The motor should run at maximum speed.
2. Turn the speed adjust potentiometer full CCW and measure the time it takes the motor to go from maximum to minimum speed.
3. If the time measured in step 2 is not the desired deceleration time, turn the DECEL trimpot CW for a slower deceleration time, or CCW for a faster deceleration time. Repeat steps 1 through 3 until the deceleration time is correct.

Application Notes

Multiple fixed speeds

Replace the speed adjust potentiometer with series resistors with a total series resistance of 10K ohms (Figure 20). Add a single pole, multi-position switch with the correct number of positions for the desired number of fixed speeds.

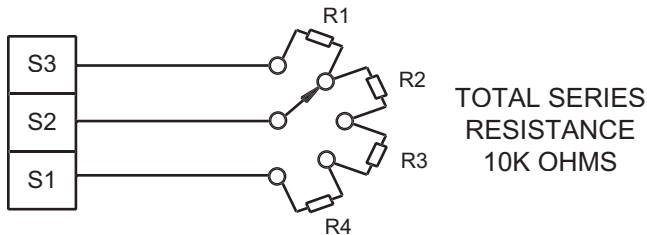

Figure 20. Multiple Fixed Speeds

Adjustable speeds using potentiometers in series

Replace the speed adjust potentiometer with a single pole, multi-position switch, and two or more potentiometers in series, with a total series resistance of 10K ohms. Figure 21 shows a connection for fixed high and low speed adjust potentiometers.

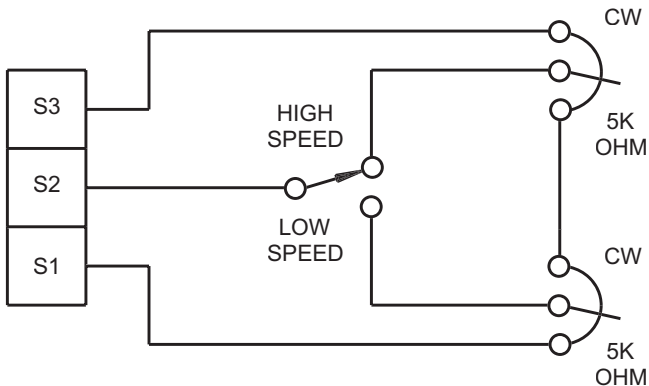

Figure 21. Adjustable Fixed Speeds Using Potentiometers in Series

Independent adjustable speeds

Replace the speed adjust potentiometer with a single pole, multi-position switch, and two or more potentiometers in parallel, with a total parallel resistance of 10K ohms. Figure 22 shows the connection of two independent speed adjust potentiometers that can be mounted at two separate operating stations.

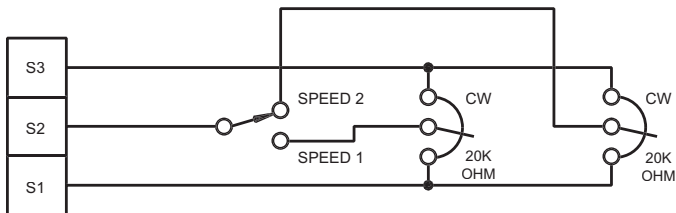

Figure 22. Independent Adjustable Speeds

RUN/JOG switch

RUN/JOG switch option #1

Using a RUN/JOG switch is recommended in applications where quick stopping is not needed and frequent jogging is required. Use a single pole, two position switch for the RUN/JOG switch, and a single pole, normally closed, momentary operated pushbutton for the JOG pushbutton.

In the first wiring option, connect the RUN/JOG switch and JOG pushbutton to the inhibit plug as shown in Figure 23. The motor coasts to a stop when the RUN/JOG switch is set to JOG. Press the JOG pushbutton to jog the motor. Return the RUN/JOG switch to RUN for normal operation.

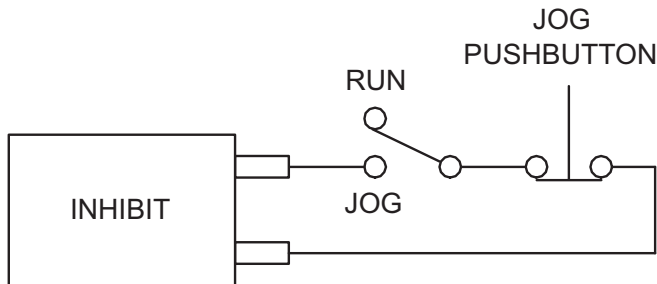

Figure 23. RUN/JOG Switch Connection to Inhibit Plug (Option #1)

RUN/JOG switch option #2

In the second wiring option, connect the RUN/JOG switch and the JOG pushbutton as shown in the Figure 24. When the RUN/JOG switch is set to JOG, the motor decelerates to minimum speed (minimum speed is determined by the MIN SPD trimpot setting). Press the JOG pushbutton to jog the motor. Return the RUN/JOG switch to RUN for normal operation.

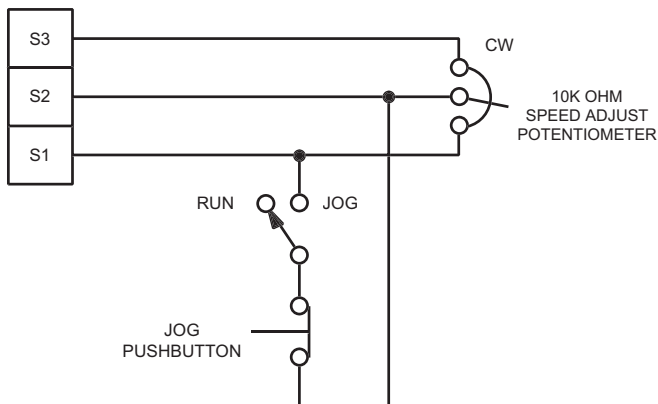

Figure 24. RUN/JOG Switch Connection to Speed Adjust Potentiometer (Option #2)

Leader-follower application

In this application, use a PCM4 to monitor the speed of the leader motor (Figure 25). The PCM4 isolates the leader motor from the follower drive, and outputs a voltage proportional to the leader motor armature voltage. The follower drive uses this voltage reference to set the speed of the follower motor. An optional ratio potentiometer may be used to scale the PCM4 output voltage.

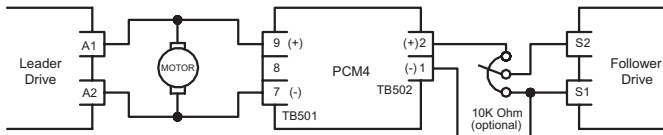

Figure 25. Leader-Follower Application

Single speed potentiometer control of multiple drives

Multiple drives can be controlled with a single speed adjust potentiometer using a PCM4 at the input of each drive to provide isolation (Figure 26). Optional ratio potentiometers can be used to scale the PCM4 output voltage, allowing independent control of each drive.

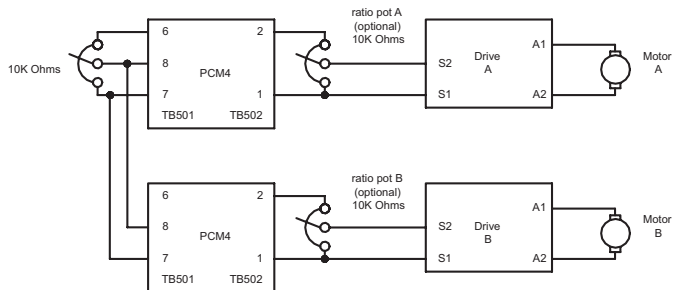

Figure 26. Single Speed Potentiometer Control of Multiple Drives

Reversing

A dynamic brake may be used when reversing the motor direction (Figure 27). Use a three pole, three position switch rated for at least the maximum DC armature voltage and maximum braking current. Wait for the motor to stop completely before switching it to either the forward or reverse direction. See the Dynamic braking section, page 41, for recommended dynamic brake resistor sizes

Note: Model MM23501 is equipped with this reversing feature.

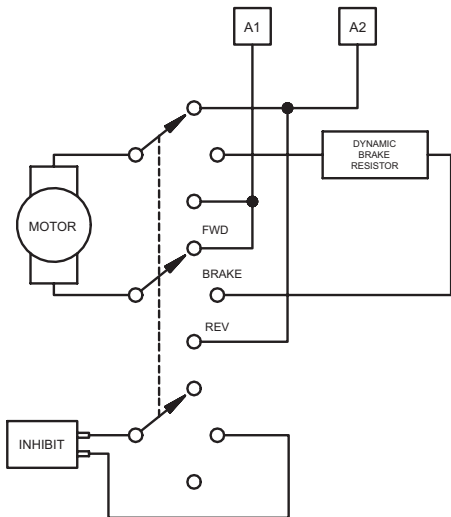

Figure 27. Reversing Circuit Connection

Reversing with a DIGI-LOK controller

A DIGI-LOK controller, model DLC600, can be used in a reversing application. The DIGI-LOK must be inhibited while braking. Without the inhibit feature, the DIGI-LOK will continue to regulate. This will cause overshoot when the DIGI-LOK is switched back to the drive.

Figure 28 shows the connection of the reversing circuit to a MM23000 series drive and to a DLC600. **Note:** Only one DLC option (Optical Encoder or Magnetic Pickup) may be used at a time.

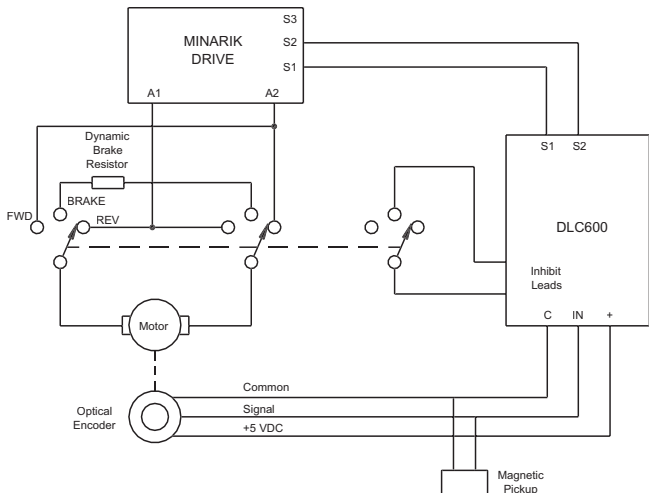

Figure 28. Reversing with a DLC600

Troubleshooting

Warning

Dangerous voltages exist on the drive when it is powered. When possible, disconnect the drive while troubleshooting. High voltages can cause serious or fatal injury.

Before troubleshooting

Perform the following steps before starting any procedure in this section:

1. Disconnect AC line voltage from the drive.
2. Check the drive closely for damaged components.
3. Check that no conductive or other foreign material has become lodged on the printed circuit board.
4. Verify that every connection is correct and in good condition.
5. Verify that there are no short circuits or grounded connections.
6. Check that the voltage selection switch settings match the AC line and output voltages.
7. Check that the drive's rated armature and field outputs are consistent with the motor ratings.

For additional assistance, contact your local Minarik Distributor, or the factory direct at: Tel.: 1-800-MINARIK (646-2745) or
Fax: 1-800-394-6334

Problem	Possible Causes	Suggested Solutions
Line fuse blows.	<ol style="list-style-type: none"><li data-bbox="387 230 636 278">1. Line fuse is the wrong size.<li data-bbox="387 335 636 408">2. Motor cable or armature is shorted to ground.<li data-bbox="387 439 650 589">3. Nuisance tripping caused by a combination of ambient conditions and high-current spikes (i.e. reversing).	<ol style="list-style-type: none"><li data-bbox="681 230 923 303">1. Check that the line fuse is correct for the motor size.<li data-bbox="681 335 940 383">2. Check motor cable and armature for shorts.<li data-bbox="681 439 940 772">3. Add a blower to cool the drive components; decrease TORQUE settings, or resize motor and drive for actual load demand, or check for incorrectly aligned mechanical components or "jams". See page 44 for information on adjusting the TORQUE trimpot.

Problem	Possible Causes	Suggested Solutions
Line fuse does not blow, but the motor does not run.	<ol style="list-style-type: none">1. Speed adjust pot or speed reference voltage is set to zero speed.2. INHIBIT terminals are jumpered.3. S2 is shorted to S1.4. Drive is in current limit.5. Drive is not receiving AC line voltage.6. Motor is not connected.	<ol style="list-style-type: none">1. Increase the speed adjust pot or speed reference voltage setting.2. Remove jumper from the INHIBIT terminals.3. Remove short.4. Verify that motor is not jammed. Increase TORQUE setting if they are set too low. See page 44.5. Apply AC line voltage to L1 and L2.6. Connect motor to A1 and A2.
Motor does not stop when the speed adjust potentiometer is full CCW.	MIN SPD setting is too high.	Calibrate MIN SPD. See page 43.
Motor runs in the opposite direction (non-reversing drives).	Motor connections to A1 and A2 are reversed.	Reverse connections to A1 and A2.

Problem	Possible Causes	Suggested Solutions
Motor runs too fast.	<ol style="list-style-type: none"> 1. MAX SPD and MIN SPD are set too high. 2. Motor field connections are loose (shunt wound motors only). 	<ol style="list-style-type: none"> 1. Calibrate MAX SPD and MIN SPD. See page 43. 2. Check motor field connections.
Motor will not reach the desired speed.	<ol style="list-style-type: none"> 1. MAX SPD setting is too low. 2. IR COMP setting is too low. 3. TORQUE setting is too low. 4. Motor is overloaded. 	<ol style="list-style-type: none"> 1. Increase MAX SPD setting. See page 43. 2. Increase IR COMP setting. See page 44. 3. Increase TORQUE setting. See page 44. 4. Check motor load. Resize the motor and drive if necessary.
Motor pulsates or surges under load.	<ol style="list-style-type: none"> 1. IR COMP is set too high. 2. Motor bouncing in and out of current limit. 	<ol style="list-style-type: none"> 1. Adjust the IR COMP setting slightly CCW until the motor speed stabilizes. See page 45. 2. Make sure motor is not undersized for load; adjust TORQUE trimpot CW. See page 44.

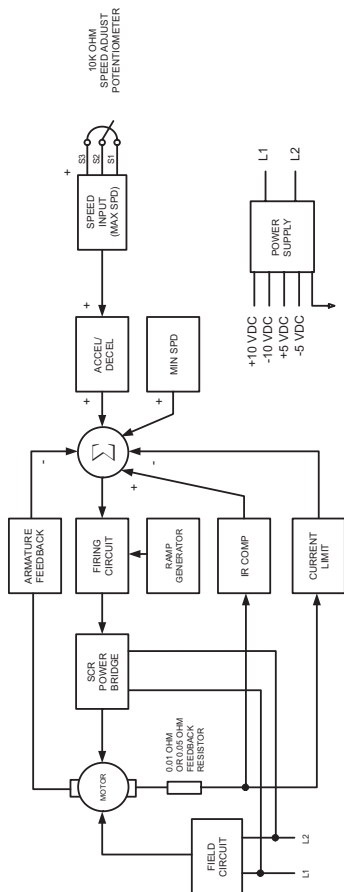
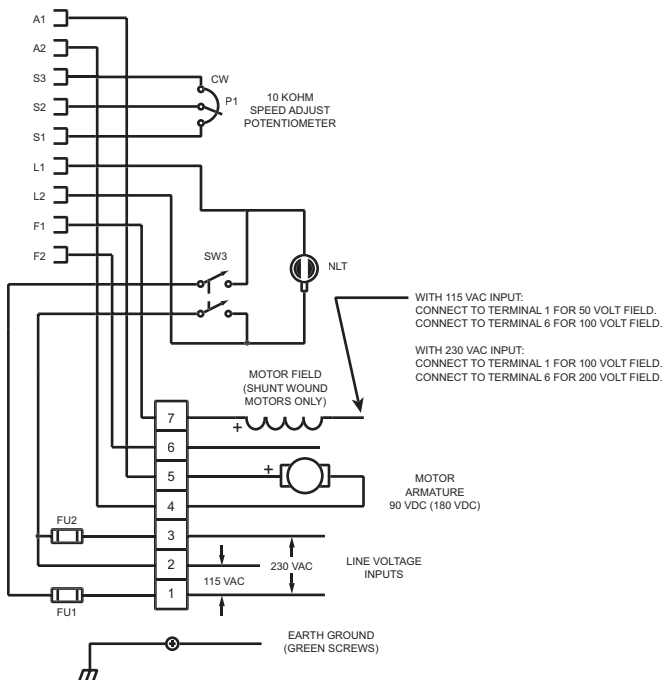

Figure 29. MM23000 Series Block Diagram



**Figure 30. MM23101, MM23111, MM23401 and MM23411
 Terminal Block Connections**

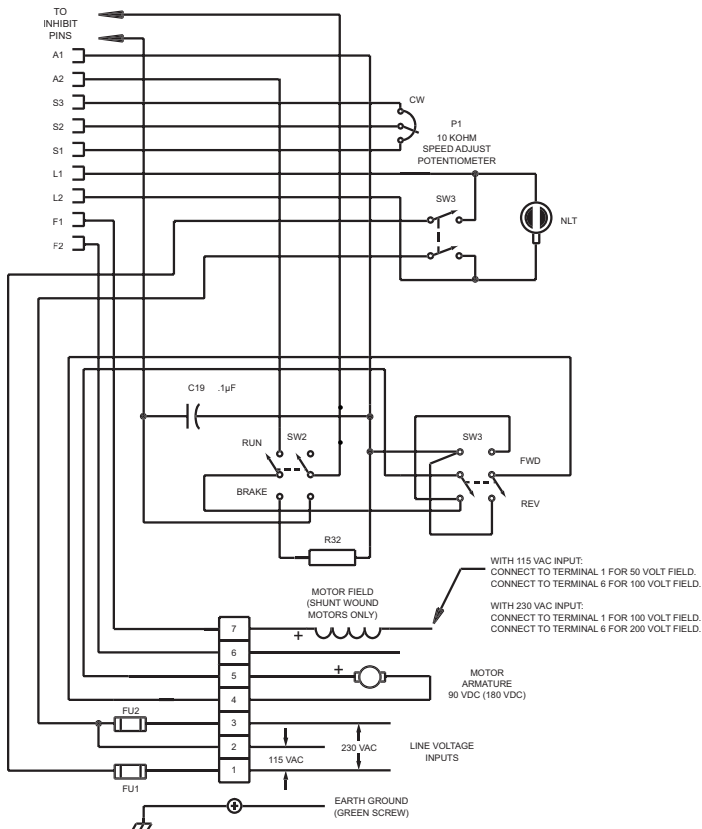

Figure 31. MM23201 and MM23211 Terminal Block Connections

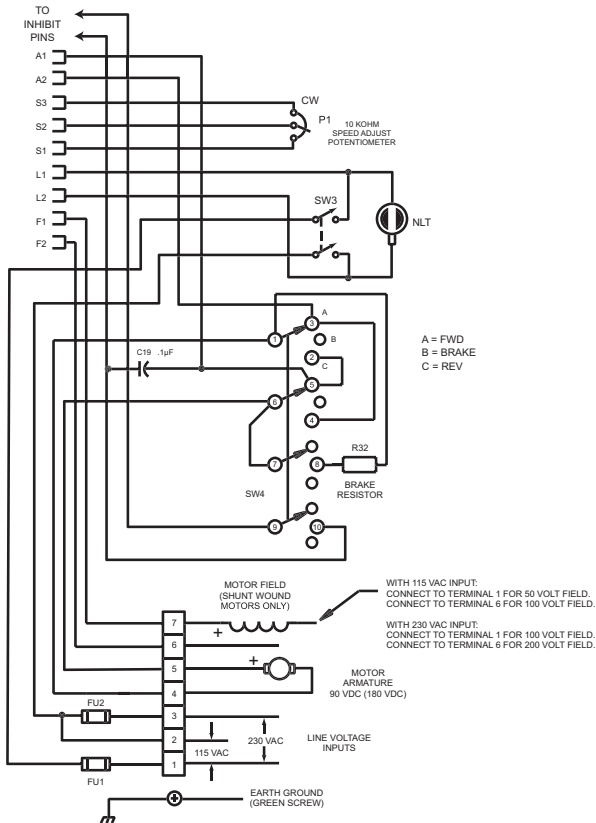

Figure 32. MM23501 Terminal Block Connections

Replacement Parts

Replacement parts are available from Minarik Corporation and its distributors for this drive series.

Table 5. Replacement Parts

Model No.	Symbol	Description	Minarik P/N
MM23001 and MM23071	SCR501, 502	800 V, 20 A SCR	072-0043
	D501-503	800 V, 20 A Diode	071-0039
	R501	0.01 OHM, 5 W Resistor	032-0129
	T501	3FD-224-001 Transformer 10KW potentiometer kit	230-0083 202-0031
MM23011	Same as MM23001 except:		
	SCR501, 502	600 V, 8 A SCR	072-0024
	D501-503	600 V, 3 A Diode	071-0007
MM23101	Same as MM23001 except potentiometer kit, and including:		
		Case Bottom	223-0170
		Case Cover	223-0169
		240V Pilot Light	040-0043
		10K OHM, 2W Potentiometer	120-0047
		Knob	140-0013
		DPST Power Switch 15 A, 3AB Fuse	080-0037 050-0018
MM23111	Same as MM23011 except potentiometer kit. Same as MM23101 except fuse. Include:		
		3 A, 3AG Fuse	050-0021
MM23201	Same as MM23101 except case cover, and including:		
		Case Cover	223-0168
		40 OHM, 40W Resistor	032-0076
	SW4	DPST Run/Brake Switch	080-0027
	SW5	DPST FWD/REV Switch	080-0027

Table 5. Replacement Parts (continued)

Model No.	Symbol	Description	Minarik P/N
MM23211		Same as MM23011 except potentiometer kit. Same as MM23201 except fuse. Include:	
		20KW, 10W Resistor	032-0043
		3 A, 3AG Fuse	050-0021
MM23411		Same as MM23011 except potentiometer kit, and including:	
		Knob	140-0013
		240V Pilot Light	040-0043
		DPST Power Switch	080-0037
		Power Switch Boot	155-0078
		10K OHM, 2 W Potentiometer	120-0047
		3A 3AG Fuse	050-0021
		Heat Sink	223-0182
		Case	223-0104
MM23401		Same as MM23001 except pot kit. Same parts as MM23411 (knob,....,case) except fuse, and including:	
		15 A, 3AB Fuse	050-0018
MM23501		Same as MM23401 except heat sink and case, and including:	
		Heat Sink	223-0183
		Case	223-0106
		20 OHM, 40 W Resistor	032-0062
		FWD/BRAKE/REV Switch	081-0010
		Knob	140-0014
MM23072		Same as MM23071 except:	
	R501	0.05 OHM, 5W Resistor	032-0089
MM23001C-Q		Same as MM23001 including:	
	SO503	Quick-Disconnect Header Block	164-0211
		Quick-Disconnect Plug	160-0095

CE Compliance

Minarik Corporation hereby certifies that its MM23000 series drives have been approved to bear the “CE” mark provided the conditions of approval have been met by the end user.

The MM23000 series has been tested to the following test specifications:

**EN55011:1991 (emissions), and
EN50082-1:1992 (immunity)**

Compliance allows Minarik's MM23000 series to bear the CE mark.

The end user, as described herein, falls into one of two categories:

1. The Consumer will deploy a stand-alone unit as an integral, yet external, portion of the machine being operated.
2. The Original Equipment Manufacturer (OEM) will implement the product as a component of the machine being manufactured.

In addition to EMI/RFI safeguards inherent in the MM23000 series' design, external filtering is required.

Line filters

Minarik requires the Corcom[®] line filters listed below.

Table 6. Corcom[®] Filters

Nameplate Current of Motor Wired to the Drive	Corcom[®] Filter Part Number
0 to 4 amps	6VV1
4.1 to 13 amps	20VV1

If the exact line filter is not available, the specifications are as follows:

L = (1.73 + 0.03) milliHenries.

C = (0.27 + 0.54) microFarads (X); 0.0055 microFarads (Y).

R = 330Kohms.

Rated current: 1.4 times maximum DC motor current.

Filter type: Balanced 2-section.

The line filters should be wired to the AC line within 0.25 meters of the drive. The ground connection from the line filter must be wired to solid earth ground (resistance less than 500 ohms); not machine ground. This is very important!

If the end-user is using a CE-approved motor, the correct line filter listed above is all that is necessary to meet the EMC directives listed herein.

Armature filters

If the end-user is not using a CE-approved motor, a second filter on the armature must be used. It is Minarik's CEXXMM. XX = rated current of the filter. Minarik Filters are listed below.

Table 7. Minarik Filters

Nameplate Current of Motor Wired to the Drive	Minarik Filter Part Number
0 to 4 amps	CE4MM
4.1 to 13 amps	CE20MM

The filters listed above are Real-Pole Balanced-Pi 3-pole filters. If the exact filter is not available, the specifications are as follows:

$L \ \& \ L1 = 2 * (0.8) \text{ milliHenries.}$

$C \ \& \ C1 = 2 * (0.1) \text{ microFarads @ 400 VDC.}$

$R_{in} = 0.1 \text{ ohm; } R_{out} = 1.2 \text{ ohm.}$

The filters listed above must be wired to the DC output of the drive, as close to the drive as possible.

The end user must use the filters listed in this section to comply with CE. The OEM may choose to provide alternative filtering that encompasses the Minarik drive and other electronics within the same panel.

The OEM has this liberty because CE is a machinery directive. Whether or not every component in the OEM's machinery meets CE, the OEM must still submit his machine for CE approval.

Thus, no component must necessarily meet CE within the machine, as long as the OEM takes the necessary steps to guarantee the machine does meet CE. By the same token, even if every component in the OEM's machine does meet CE, the machine will not necessarily meet CE as a machine.

Using CE-approved wiring practices (like proper shielding) and the filters listed in this section help the drive meet EN55011 (1991 emissions standard) and EN50082-1 (1992 immunity standard).

NOTES

NOTES

NOTES

Unconditional Warranty

A. Warranty - Minarik Corporation (referred to as "the Corporation") warrants that its products will be free from defects in workmanship and material for twelve (12) months or 3,000 hours, whichever comes first, from date of manufacture thereof. Within this warranty period, the Corporation will repair or replace, at its sole discretion, such products that are returned to Minarik Corporation, 901 East Thompson Avenue, Glendale, CA 91201-2011 USA.

This warranty applies only to standard catalog products, and does not apply to specials. Any returns for special controls will be evaluated on a case-by-case basis. The Corporation is not responsible for removal, installation, or any other incidental expenses incurred in shipping the product to and from the repair point.

B. Disclaimer - The provisions of Paragraph A are the Corporation's sole obligation and exclude all other warranties of merchantability for use, express or implied. The Corporation further disclaims any responsibility whatsoever to the customer or to any other person for injury to the person or damage or loss of property of value caused by any product that has been subject to misuse, negligence, or accident, or misapplied or modified by unauthorized persons or improperly installed.

C. Limitations of Liability - In the event of any claim for breach of any of the Corporation's obligations, whether express or implied, and particularly of any other claim or breach of warranty contained in Paragraph A, or of any other warranties, express or implied, or claim of liability that might, despite Paragraph B, be decided against the Corporation by lawful authority, the Corporation shall under no circumstances be liable for any consequential damages, losses, or expense arising in connection with the use of, or inability to use, the Corporation's product for any purpose whatsoever.

An adjustment made under warranty does not void the warranty, nor does it imply an extension of the original 12-month warranty period. Products serviced and/or parts replaced on a no-charge basis during the warranty period carry the unexpired portion of the original warranty only.

If for any reason any of the foregoing provisions shall be ineffective, the Corporation's liability for damages arising out of its manufacture or sale of equipment, or use thereof, whether such liability is based on warranty, contract, negligence, strict liability in tort, or otherwise, shall not in any event exceed the full purchase price of such equipment.

Any action against the Corporation based upon any liability or obligation arising hereunder or under any law applicable to the sale of equipment or the use thereof, must be commenced within one year after the cause of such action arises.

Other drives from Minarik Corporation:

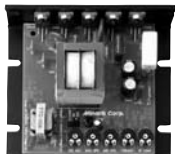

PCM2000 Series



DLC600



MM-PCM Series

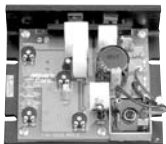
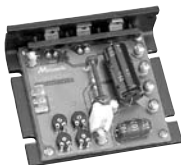

XP Series
(AC or DC Input)



14300 DeLaTour Dr, South Beloit IL 61080
PHONE: 800-646-2745, FAX: 800-394-6334
www.minarikdrives.com

Document number 250-0091, Revision 8
Printed in the U.S.A – 1/05