



VFD SERIES

Variable-frequency
drives
for 3-phase and
single-phase
AC motors

VFD05-D230-PCM
VFDP4X04-D230-PCM
VFDA4X04-D230-PCM
VFDF4X04-D230-PCM

Copyright © 2004 by
Minarik Drives

All rights reserved. No part of this manual may be reproduced or transmitted in any form without written permission from Minarik Drives. The information and technical data in this manual are subject to change without notice. Minarik Drives and its Divisions make no warranty of any kind with respect to this material, including, but not limited to, the implied warranties of its merchantability and fitness for a given purpose. Minarik Drives and its Divisions assume no responsibility for any errors that may appear in this manual and make no commitment to update or to keep current the information in this manual. KC0304

Printed in the United States of America.

Layouts

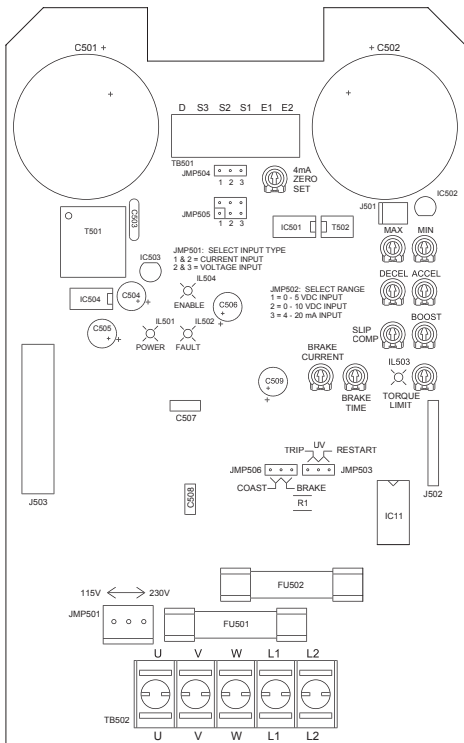

Figure 5. VFDA4X04 and VFDF4X04-D230-PCM Circuit Board Layout

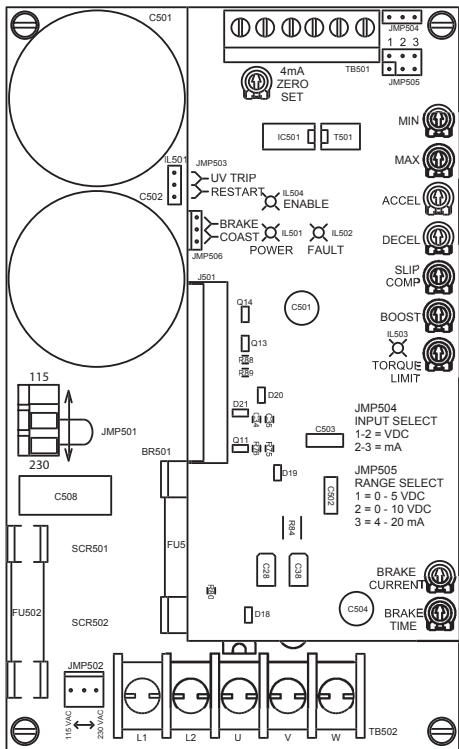

Figure 6. VFD4X04-D230-PCM Circuit Board Layout

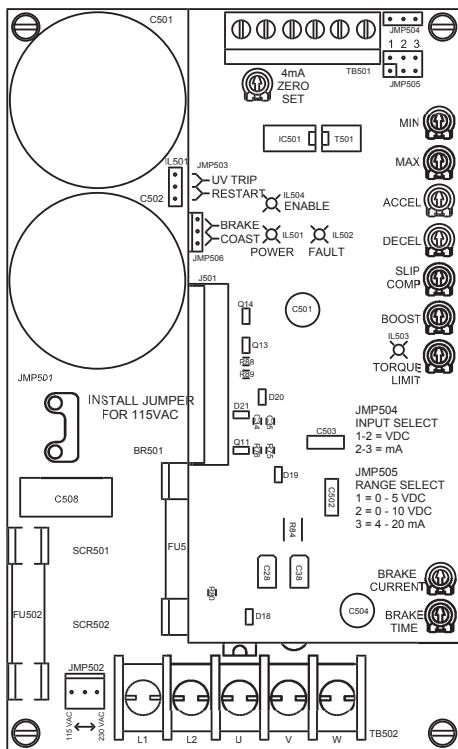

Figure 7. VFD05-D230-PCM Circuit Board Layout

Jumper Locations

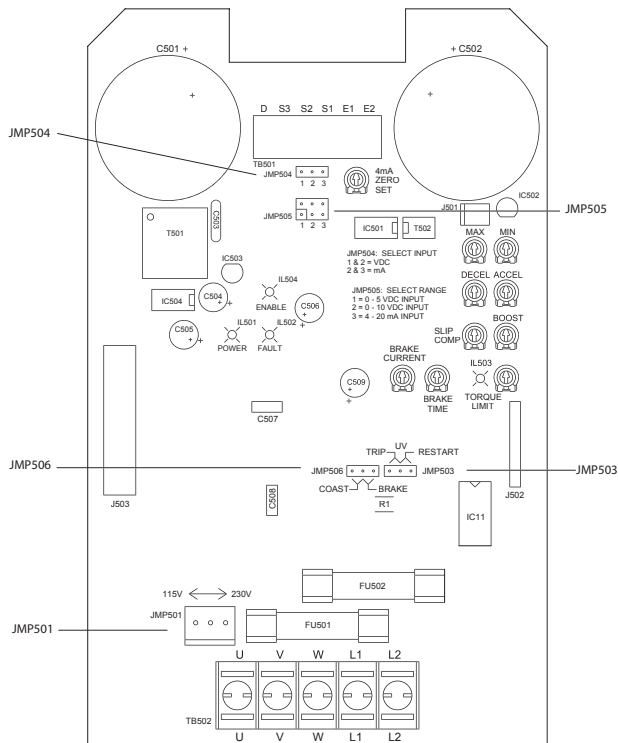

Figure 8. VFDA4X04 and VFDF4X04 Jumper Locations

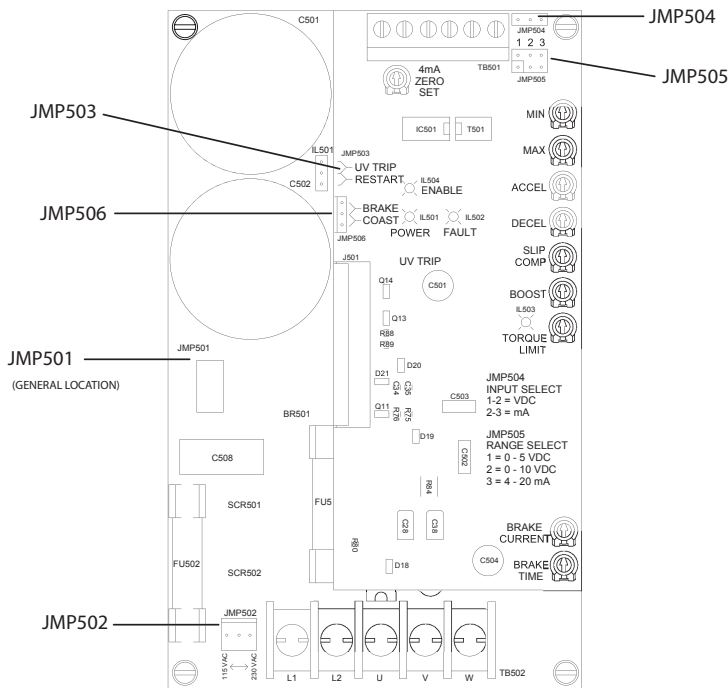

Figure 9. VFDP4X04 and VFD05 Jumper Locations

Installation



Warning



DO NOT install, rewire, or remove this control with input power applied. Failure to heed this warning may result in fire, explosion, or serious injury.

Circuit potentials are at 115 or 230 VAC above ground. To prevent the risk of injury or fatality, avoid direct contact with the printed circuit board or with circuit elements.

Do not disconnect any of the motor leads from the drive unless power is removed. Opening any one motor lead may damage the drive.

Wait at least one minute after power is removed from drive before working on drive.

- It is recommended that tape be applied to the back side of the conduit knockouts before knocking the two holes out to shield the drive from metal shavings. Surface should be cleaned of all metal shavings and other metal coating material before installation.

Mounting



Warning

DO NOT install, rewire, or remove this control with input power applied. Doing so may cause fire or serious injury. Make sure that you read and understand the Safety Warnings before attempting installation.

NOTE: Horizontal mounting may require derating the drive. See your Minarik representative for more information

- It is recommended that the drive be oriented with the chassis vertical for best heat dissipation. Horizontal mounting, while acceptable, may require some thermal derating.
- Four 0.19-inch (5 mm) wide slots accept #8 pan head screws. Fasten the heatsink chassis to the subplate.
- Drive components are sensitive to electrostatic fields. Avoid direct contact with the circuit board. Hold the drive by the chassis only.

- Protect the drive from dirt, moisture, and accidental contact. Provide sufficient room for access to the terminal block and calibration trimpots.
- Mount the drive away from the heat sources. Operate the drive within the specified ambient operating temperature range.
- Prevent loose connections by avoiding excessive vibration of the drive.
- The chassis must be earth grounded. Use a star washer beneath the head of at least one of the mounting screws to penetrate the anodized chassis surface and to reach bare metal.

Wiring



Warning



DO NOT install, rewire, or remove this control with input power applied. Failure to heed this warning may result in fire, explosion, or serious injury.

Circuit potentials are at 115 or 230 VAC above ground. To prevent the risk of injury or fatality, avoid direct contact with the printed circuit board or with circuit elements.

Do not disconnect any of the motor leads from the drive unless power is removed. Opening any one motor lead may damage the drive.

Wait at least one minute after power is removed from drive before working on drive.

- Use 20 – 24 AWG wire for speed adjust potentiometer wiring. Use 14 AWG wire for AC line (L1, L2) and motor (U,V and W) wiring.

Shielding guidelines



Warning

Under no circumstances should power and logic leads be bundled together. Induced voltage can cause unpredictable behavior in any electronic device, including motor controls.

As a general rule, Minarik recommends shielding of all conductors.

If it is not practical to shield power conductors, Minarik recommends shielding all logic-level leads. If shielding the logic leads is not practical, the user should twist all logic leads with themselves to minimize induced noise.

It may be necessary to earth ground the shielded cable. If noise is produced by devices other than the drive, ground the shield at the drive end. If noise is generated by a device on the drive, ground the shield at the end away from the drive. Do not ground both ends of the shield.

If the drive continues to pick up noise after grounding the shield, it may be necessary to add AC line filtering devices, or to mount the drive in a less noisy environment.

Logic wires from other input devices, such as motion controllers and PLL velocity controllers, must be separated from power lines in the same manner as the logic I/O on this drive.

Heat sinking

All VFDx4X04/VFD05-series drives are delivered with a heat sink chassis. Ensure that there is adequate space above and below the drive for proper convection air flow. A small fan may be necessary for proper cooling in restricted space applications.

Fusing

VFD series drives include AC power line fuses on the main PC Board. Use fast-acting fuses rated for 250 VAC or higher. See Table 1 for recommended line fuse sizes.

Table 1. Line Fusing Chart

Drive	1-Phase Input (VAC)	Max HP	AC Amps In	AC Line Fuse Size (Amps)
VFDx4X04-D230-PCM	115 / 230	1	14/7	15
VFD05-D230-PCM	115 / 230	1½	20/10	20

Speed adjust potentiometer (VFD05-D230-PCM Only)

Mount the speed adjust potentiometer through a 0.38 in. (10 mm) hole with the hardware provided (Figure 10). Install the circular insulating disk between the panel and the 10K ohm speed adjust potentiometer. Twist the speed adjust potentiometer wire to avoid picking up unwanted electrical noise. If speed adjust potentiometer wires are longer than 18 in. (457 mm), use shielded cable. Keep speed adjust potentiometer wires separate from power leads (L1, L2, U, V, W).

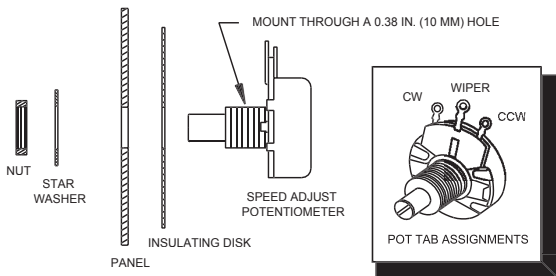

Figure 10. Speed Adjust Potentiometer

Connections

All power input and power output connections are made to TB502.



Warning

DO NOT connect this equipment with power applied. Failure to heed this directive may result in fire or serious injury.

Minarik strongly recommends the installation of a master power switch in the voltage input line. The switch contacts should be rated at a minimum of 200% of motor nameplate current and 250 volts.

Input AC Power connections

Connect the AC power input to TB502 L1 and L2 as shown in Figures 11 and 12 (page 19). Connect an external master stop switch. Install the switch between the external AC power input as shown.

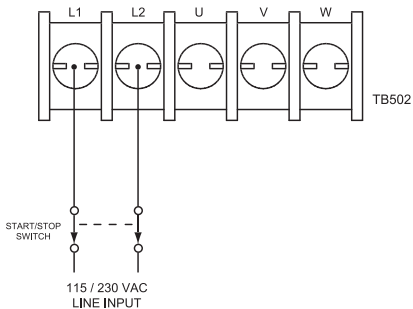

Figure 11. AC Line Connections for VFD05 and VFDP4X04

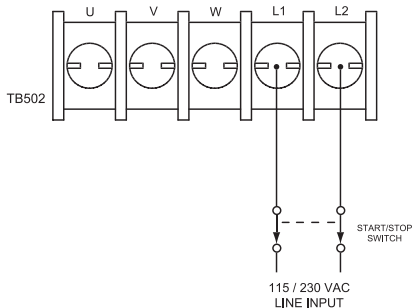

Figure 12. AC Line Connections for VFDA4X04 and VFDF4X04

Warning

Do not connect 230 VAC line input when the drive is set for 115 VAC input. This will result in severe damage to the motor. and can lead to explosion and/or injury.



Connect AC Power input to L1 and L2 as shown in Figures 11 and 12 (page 19), depending on the model of drive being usedbvg.

NOTE: The VFDx4X and VFD05 series drives are equipped with a voltage-doubler feature, which converts a 115 VAC input to a 230 VAC output, for use with 230V motors. The drive output current rating remains the same for either AC input voltage. Use caution when connecting this output.

If the input voltage is 115 VAC and the desired output voltage is 230 VAC (voltage doubler mode), set jumpers as shown in Figures 13 -15 (page 21).

If the input voltage is 230 VAC and the desired output voltage is 230 VAC (no voltage doubler), set jumpers as show in Figure 13 -15 (page 21).

Refer to Figures 8 and 9 (pages 8 and 9) for jumper locations.

NOTE: The VFD series of drives covered in this manual are meant to be used with 208/230 VAC motors only. **DO NOT** use this series of drives with 115 VAC motors.

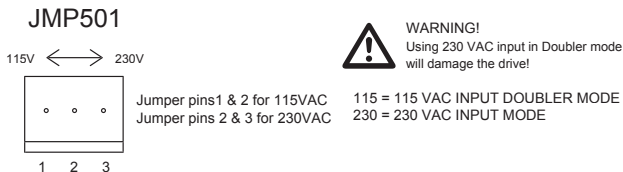

Figure 13. Voltage Doubler Feature for VFDA4X04 and VFDF4X04

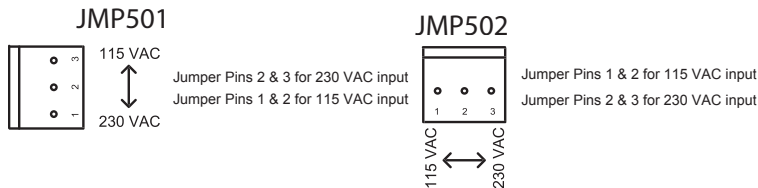

Figure 14. Voltage Doubler Feature for VFDP4X04

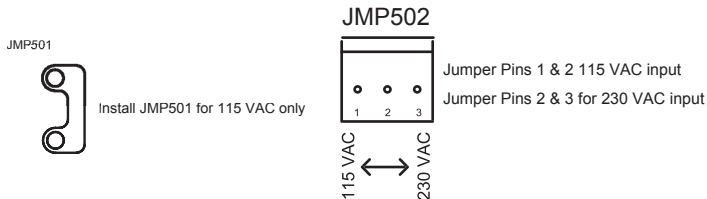

Figure 15. Voltage Doubler Feature for VFD05

Motor connections (all VFD-series controls)

Motor connections are made to TB502

Single-phase operation

For single-phase operation, connect the motor as shown below in Figure 16. Ensure that the prewired capacitor and its associated motor coil are connected to terminals U and V as shown. This connection may be internal if using a 2-wire motor. If the motor has three leads, you must make this connection yourself.

To reverse a single phase permanent split capacitor motor, connect the motor as shown in Figure 17 (page 23). The motor cap must be removed from the circuit.

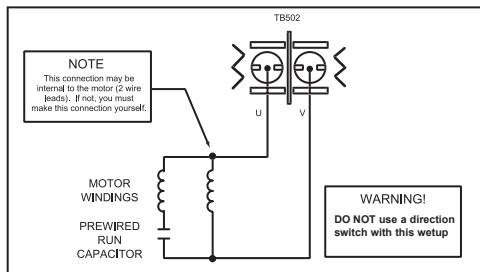

Figure 16. Single Phase Operation (pre-wired cap)

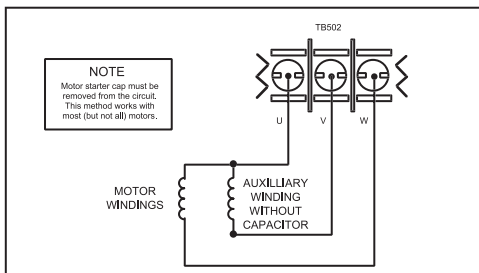

Figure 17. Single Phase Operation (Reversing)

Three-phase operation

Connect a three-phase motor to terminals U, V and W as shown in Figure 18 below.

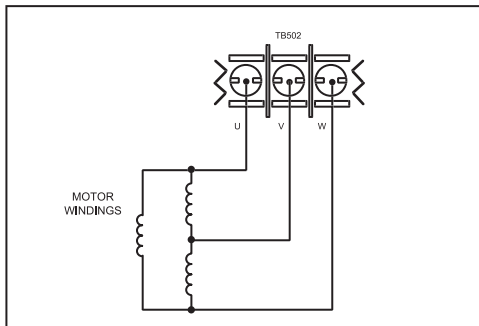

Figure 18. Three-phase Operation

Speed Adjust Potentiometer Connections

Set JMP504 for VDC input by jumpering pins 1 & 2. Set JMP505 for 0-5VDC by jumpering pin column 1. Refer to Figures 8 and 9 (pages 8 and 9) for Jumper Locations. Connect a speed adjust potentiometer to terminals S1, S2 and S3. Make sure the potentiometer is connected so that the motor speed will increase as the potentiometer is turned clockwise. See Figure 19 below.

NOTE: These settings and connections are factory installed on the VFDx4X04-D230-PCM drives.

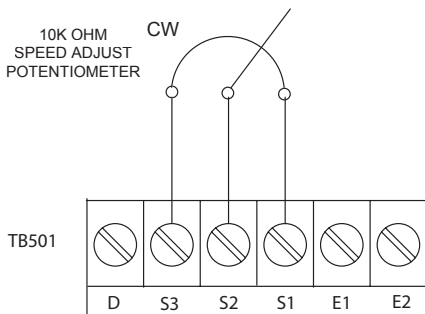

Figure 19. Speed Adjust Potentiometer Connections to TB501 for VFDx4X04

Signal and Optional Switch Connections

All signal and switch connections are made at TB501. Terminal block names are identical for all VFDx-4X04/VFD05 -D230-PCM series drives. Use 20 - 24 AWG wire for speed adjust potentiometer and switch connections.

NOTE: The Enable/Disable and Direction switch are factory installed on the VFDx4X04-D230-PCM drives.

ENABLE/DISABLE switch

Connect a single-pole, single-throw ENABLE/DISABLE switch between the ENABLE (E2) and COMMON (E1) terminals as shown. Open the switch to disable the drive and coast or brake to a stop. Refer to (page 32) for stopping method. Close the switch to accelerate to set speed at a rate controlled by the ACCEL trimpot.

DIRECTION (D) switch

Connect a single-pole, single-throw DIRECTION switch between the (D) and COMMON (E1) terminals as shown in Figure 20 (page 26). Opening the switch will cause the motor to rotate in the forward direction; closing the switch will reverse motor rotation.

The drive will decelerate the motor to a stop, (at the DECEL trimpot setting), before reversing, so there is no need to wait for the motor to coast or brake to a stop before changing direction. For faster reversing see Application Notes (page 48).

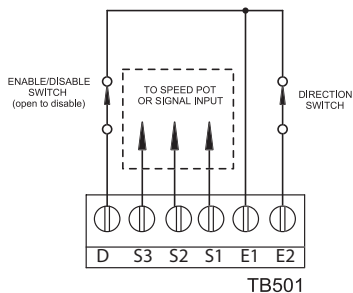

Figure 20. Signal and Optional Switch Connections for VFDx4X04 and VFD05

Voltage or Current Follower

Drives can be configured to follow an isolated or a grounded (non-isolated) voltage or current signal. To configure the drive to follow a voltage or current signal, connect the signal leads to the S1 and S2 terminals on TB501 as shown in Figure 20 above. Ensure that the following jumper terminals are properly set as shown in Figure 21 (page 27).

JMP504 Input Type

Jumper pins 1 & 2 for Voltage follower or speed pot mode.

Jumper pins 2 & 3 for Current follower.

JMP505 Input Range Settings

Set jumper in position 1 for 0-5 VDC signal or speed pot input.

Set jumper in position 2 for 0-10 VDC signal or speed pot input.

Set jumper in position 3 for 4-20 mA signal. *

* The 4-20 mA ZERO SET potentiometer should be used to calibrate the zero (or minimum) speed of the drive with 4mA applied to the input. For voltage inputs this pot should be set to full CCW.

JMP504

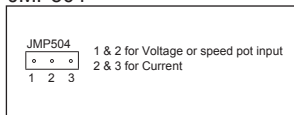

JMP505

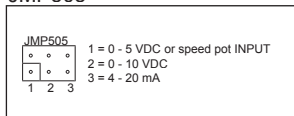

Figure 21. Jumper Settings--JMP504 and JMP505

Operation



Warning



Dangerous voltages exist on the drive when it is powered, and up to 60 seconds after power is removed and the motor stops. BE ALERT. High voltages can cause serious or fatal injury.

Do not change jumper settings with power applied. Ensure that jumper settings are compatible with the motor being controlled.



Voltage Input Warning



DO NOT connect 230 VAC line input when the drive is set for 115 VAC input. This will result in severe damage to the motor and drive, and possible explosion and/or injury.

Voltage Doubler



Warning

DO NOT connect 230 VAC line input when drive is set for 115 VAC input. This will result in severe damage to the motor and drive, and possible explosion or severe injury.

The VFD05-D230-PCM and VFDx4X04-D230-PCM series drives are equipped with a unique voltage-doubling feature, for use when 230 VAC input voltage is not available. This feature converts a 115 VAC input to a 230 VAC output, for use with 230V motors. The drive output current rating remains the same for either AC input voltage.

Refer to Figure 13-15 (page 21) for connection information. Use extreme caution when connecting this feature. Incorrect use of this feature may result in fire and/or serious injury.

NOTE: The VFD series of drives covered in this manual are meant to be used with 208/230 VAC motors only. **DO NOT** use this series of drives with 115 VAC motors.

Startup



Warning

DO NOT change jumper settings with power applied. Ensure that jumper settings are compatible with the motor being controlled.

Before applying power, verify that no conductive material is present on the printed circuit board.

1. Verify that no conductive material is present on the PCB.
2. Verify that the correct voltage is connected to the inputs before applying power. **DO NOT CONNECT 230 VAC** line voltage to a 115 VAC configured drive. Applying power in this manner will damage the motor and drive.
3. Set the speed adjust potentiometer or reference signal to zero (full CCW).
4. Set the DIRECTION switch (if installed) to the desired direction. If no switch is installed, add or remove a jumper across the (D) and (E1) terminals, as required.
5. Set the ENABLE/DISABLE switch (if installed) to ENABLE, or short the ENABLE (E2) and (E1) terminals on TB501.
6. Apply 115 or 230 VAC, 50/60 Hz, single-phase power to the drive. The green POWER LED will come on after an initial delay of 1 - 2 seconds. If the POWER LED does not light, check the line fuses to ensure that they are properly installed and not open.

7. If you attempt to startup and the yellow TQ LED comes on, the control has entered torque limit mode. To avoid this occurrence, you may:
 - a. increase the torque limit setting*, or
 - b. lengthen the acceleration time enough to accommodate the starting torque needed by adjusting the ACCEL trimpot.

* Do not set the torque limit setting above 150% of the motor's nameplate current rating.

To reverse motor direction:

To reverse the direction of motor shaft rotation while the motor is running, set the DIRECTION switch to the opposite position. If no DIRECTION switch is installed, open or short the (DIR) and (E1) terminals on TB501, as required.

When a new direction is selected, there is no need to open the enable input. The control will automatically decelerate the motor to zero speed, reverse direction, and then accelerate the motor back to the set speed. Acceleration and deceleration rates are controlled by the ACCEL/DECEL trimpot settings. If quicker reversing is needed refer to applications notes section (page 45) for further detail.

NOTE: DO NOT use the DIRECTION switch if there is a capacitor in the motor windings.

Starting and stopping methods

(factory set to COAST position)

To coast the motor to a stop

Insure that JMP506 is set to the COAST position as shown in Figures 22 and 23 (page 33). Refer to Figure 8 and 9 (page 8 and 9) for Jumper Locations. To coast the motor to a stop open the ENABLE/DISABLE switch, or remove the jumper between ENABLE (E2) and COMMON (E1) terminals of TB501. Refer to (page 25) for instructions on switch installation.

To brake the motor to a stop

Insure that JMP506 is set to the BRAKE position as shown in Figures 22 and 23 (page 33). Refer to Figure 8 and 9 (page 8 and 9) for Jumper Locations. Confirm BRAKE CURRENT and BRAKE TIME potentiometers are calibrated to a desired value. BREAK CURRENT is adjustable from 0-100% of rated output current. BRAKE TIME is adjustable from 1 -12 seconds. To brake the motor, open the ENABLE/DISABLE switch, or remove the jumper between ENABLE (E2) and COMMON (E1) terminals of TB501. Refer to (page 25) for instructions on switch installation.

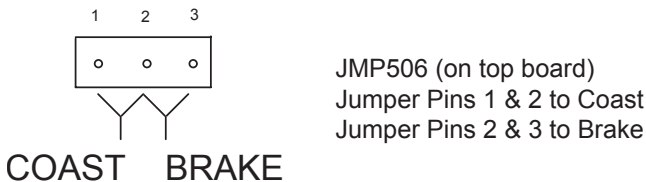

Figure 22. VFDA4X04 and VFDF4X04 Jumper Settings--JMP506



Figure 23. VFDP4X04 and VFD05 Jumper Settings--JMP506

Thermal protection of the motor

The enable input can also act as a motor thermal protection circuit for motors having a built-in thermal protector. These thermal protectors are operated only by motor heat and open the enable circuit when the motor reaches a temperature capable of causing damage to the motor winding.

Normally, these thermal procedures automatically close the circuit when the motor has cooled to a safe temperature. In operation, the drive can be disabled by opening the enable switch or opening the thermal overload switch. See Figure 24 below.

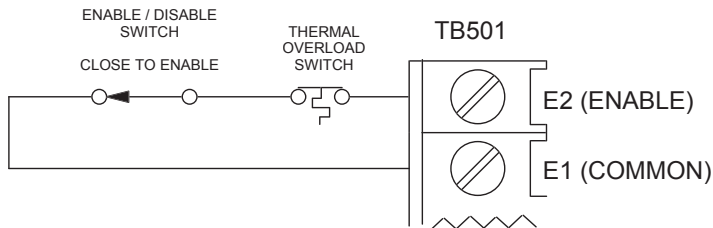

Figure 24. Thermal Overload Switch with Optional Enable / Disable Switch

VFDA4X & VFDF4X RUN/JOG Switch

The VFDA4X/VFDF4X come with a factory supplied RUN/JOG switch. To jog, the START/STOP switch must be set to stop. Press the RUN/JOG pushbutton down to jog and release to stop.

Line starting and line stopping



Warning

Minarik strongly recommends the installation of a master power switch in the voltage input line (see Power and Fuse connections, page 12). The switch contacts should be rated at a minimum of 200% of motor nameplate current and 250 volts.

Line starting/line stopping (applying and removing AC voltage input) may be configured to operate two different ways by use of JMP503.

When JMP503 is set to the UV TRIP position as shown in Figure 25 (page 36), the drive will stop and latch off when an under voltage condition, (bus voltage drops below 200VDC), occurs. This can occur due to line sag, line transients, or line disconnect. The drive may then be restarted by cycling the ENABLE off then on, or waiting until the DC bus drops to zero, (approximately 1 minute), at which point the drive will restart upon reapplication of line power. Refer to Figures 8 and 9 (pages 8 and 9) for Jumper Locations.

When JMP503 is set to the RESTART position as shown in Figure 25 below (factory set to UV trip), the drive will stop when an under voltage condition, (bus voltage drops below 200 VDC), occurs. This can occur due to line sag, line transients, or line disconnect. A timer, (1.5 seconds), is started which allows an automatic restart if the bus voltage has returned to proper operation potential. Refer to Figures 8 and 9 (pages 8 and 9) for Jumper Locations.

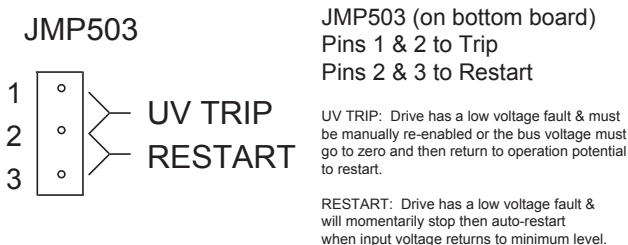

Figure 25. Jumper Settings--JMP503

Calibration



Warning



Dangerous voltages exist on the drive when it is powered, and up to 60 seconds after power is removed and the motor stops. When possible, disconnect the voltage input from the drive before adjusting the trimpots. If the trimpots must be adjusted with power applied, use insulated tools and the appropriate personal protection equipment. **BE ALERT.** High voltages can cause serious or fatal injury.

The VFD series has ten user-adjustable trimpots. Each drive is factory calibrated to its maximum horsepower rating. Re-adjust the calibration trimpot settings to accommodate lower horsepower motors. See Figures 26 and 27 (pages 38 and 39) for VFD series trimpot locations.

All adjustments increase with clockwise (CW) rotation and decrease with counter-clockwise (CCW) rotation. Use a non-metallic screwdriver for calibration. Each trimpot is identified on the printed circuit board.

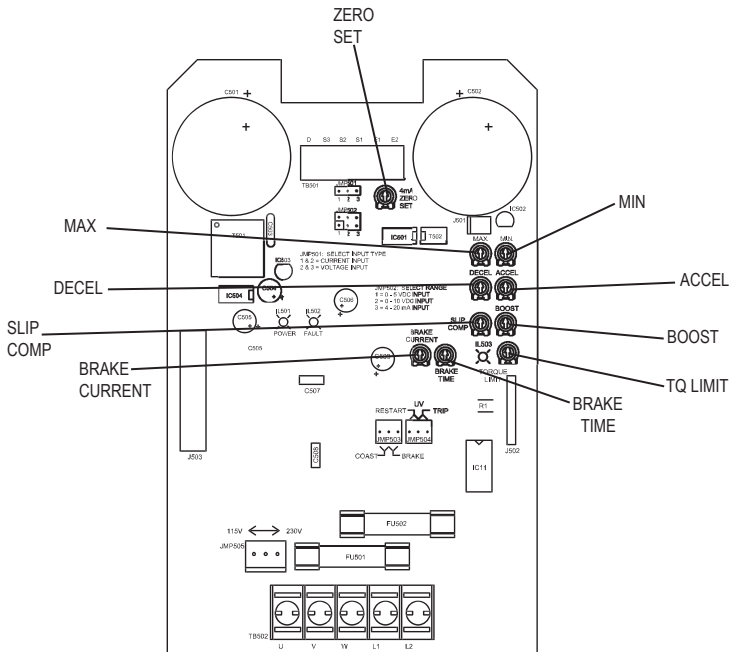

Figure 26. VFDA4X04 and VFDF4X04 Calibration Trimpot Locations

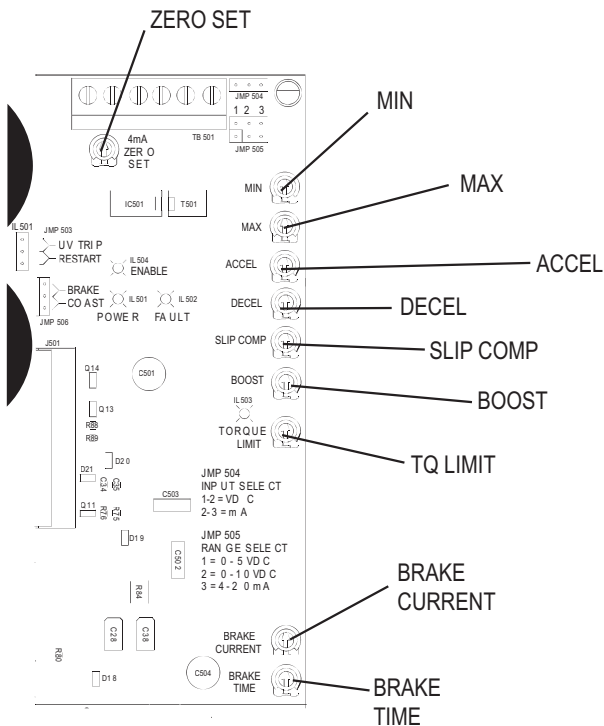

Figure 27. VFD4X04 and VFD05 Calibration Trimpot Locations

Calibration Procedure Setup for 60 Hz Motors:

1. Set JMP501 & JMP502** to appropriate input voltage setting (115/230VAC). Refer to Figures 8 and 9 (pages 8 and 9) for Jumper Locations.
2. Set the ENABLE switch to the DISABLE (open) position. If no switch is installed, remove the jumper between the (E2) and (E1) terminals of TB501.
3. Set the DIRECTION switch to the FWD (open) position. If no switch is installed, confirm that there is no jumper between the (D) and (E1) terminals of TB501.
4. Set all trimpots except TQ LIMIT and MAX fully counterclockwise (CCW).
5. Set the TQ LIMIT trimpot to maximum (full CW).
6. Set the MAX trimpot to the 50% position.
7. Set the speed adjust potentiometer or reference signal to zero (full CCW):
8. Calibrate the trimmer pots as follows:

**JMP502 is not present on VFDA4X04/VFDF4X04 models.

MAXIMUM SPEED (MAX SPD)

Rotate the speed adjust potentiometer full CW or set the reference signal to MAX. Using a hand-held tachometer or analog frequency meter as a reference, adjust the MAX trimpot until the desired maximum speed or frequency is reached.

MINIMUM SPEED (MIN)

Rotate the speed adjust potentiometer CCW or set the signal reference to a minimum. Adjust the MIN trimpot until the motor has stopped (for zero speed setting), or until desired minimum speed has been reached.

TORQUE LIMIT (TQ LIMIT)



Warning

Although the TORQUE LIMIT trimpot can be set up to 150% of the drive nameplate rating, continuous operation beyond the drive nameplate rating may cause damage to the motor and/or drive.

1. With no power applied to the drive, connect a (true RMS) ammeter in series with one of the motor leads.
2. Set the TQ LIMIT trimpot to full CCW.
3. Carefully lock the motor shaft. Ensure that the motor is firmly mounted.
4. Apply line power. The motor should be stopped.
5. Set the speed adjust potentiometer or reference signal to maximum speed. The motor should remain stopped.
6. Slowly rotate the TQ LIMIT trimpot clockwise (CW) until the ammeter reads 120% of maximum motor current.

7. Set the speed adjust potentiometer or reference signal to zero speed.
8. Remove power from the drive.
9. Remove the lock from the motor shaft.
10. Remove the ammeter in series with the motor lead.

ACCELERATION (ACCEL)

1. Set the speed adjust potentiometer or reference signal to zero and wait for the motor to come to a stop (or minimum speed).
2. Set the speed adjust potentiometer or reference signal to maximum speed (full CW) and note the time the motor takes to accelerate to maximum speed.
3. If the acceleration time differs from the desired time, adjust the ACCEL trimpot until the desired time is reached. Rotating the ACCEL trimpot CW increases the acceleration time.

DECELERATION (DECEL)

1. Set the speed adjust potentiometer or reference signal to maximum (full CW) and wait for the motor to reach maximum speed.

2. Set the speed adjust potentiometer or reference signal to minimum speed (full CCW) and note the time the motor takes to decelerate to minimum speed.
3. If the deceleration time differs from the desired time, adjust the DECEL trimpot until the desired time is reached. Rotating the DECEL pot CW increases the deceleration time.

BOOST

The BOOST trimpot is used to increase motor torque at low speeds. The minimum setting is sufficient for most applications and does not need to be adjusted. If the motor stalls or runs erratically at very low speeds (below 10 Hz), the boost trimpot may need adjustment.

1. Run the motor at the lowest continuous frequency/speed required.
2. Monitor the motor phase current (with a true RMS meter) while very slowly turning the BOOST trimpot CW until the motor operates properly, or 100% of the motor nameplate current is reached.

NOTE: Use the absolute minimum amount of BOOST necessary to achieve proper motor operation. Improper use of the BOOST feature may cause motor and/or drive overheating and failure. If proper motion operation cannot be achieved with the above procedure, please contact your Minarik representative.

SLIP COMPENSATION (SLIP COMP)

Slip compensation is used to minimize the normal speed changes occurring in an induction motor from no load to full load conditions.

1. Using the speed adjust potentiometer or reference signal, run the motor at the desired RPM under a no load condition. Measure the RPM with a tachometer.
2. Without changing the speed adjust potentiometer or reference signal, apply a full load to the motor, and bring the motor speed back up using the SLIP COMP pot to the originally measured RPM.
3. These procedures, (1&2), may need to be repeated several times to reach the desired accuracy required.**

**Wide speed range accuracy of the slip compensation method depends heavily on motor slip vs. frequency characteristics.

Calibration Procedure Conclusion

1. Set the speed adjust potentiometer or reference signal to zero (full CCW).
2. Disable the drive by opening the ENABLE/DISABLE switch or removing the jumper from TB501 (E2) and (E1) terminals.
3. Remove power to the motor and drive. Calibration is now complete.

Application Notes

Independent adjustable speeds with DIR switch

Replace the speed adjust potentiometer with two single-pole multi-position switches, and two or more potentiometers in parallel, with a total parallel resistance of 10K ohms. Figure 28 below shows the connection of two independent speed adjust potentiometers that can be mounted at two separate operating stations.

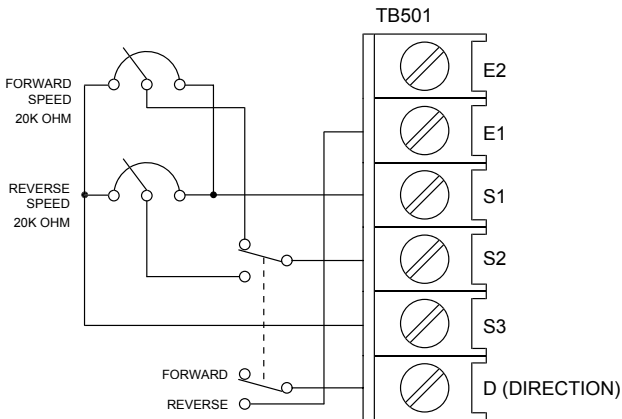

Figure 28. Independent Adjustable Speeds

RUN/JOG switch

Using a RUN/JOG switch is recommended in applications where quick stopping is not needed and frequent jogging is required. Use a single-pole, two-position switch for the RUN/JOG switch, and a single-pole, normally open, momentary operated pushbutton for the JOG pushbutton.

Connect the RUN/JOG switch and JOG pushbutton to terminal board TB501 as shown in Figure 29 below. The motor stops when the RUN/JOG switch is set to JOG. Press the JOG pushbutton to jog the motor. Return the RUN/JOG switch to RUN for normal operation.

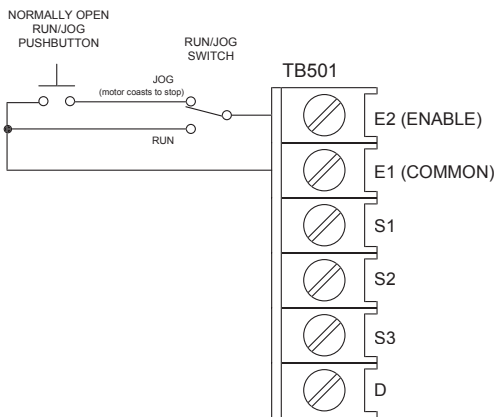

Figure 29. RUN/JOG Switch

Single speed potentiometer control of multiple motors



Warning

The combined current draw of all motors must not exceed the current rating of the drive.

The VFD series of controls is capable of operating up to eight 3-phase motors simultaneously. All motors must be of the same type and must control similar loads. Connect each motor as shown in Figure 30 below.

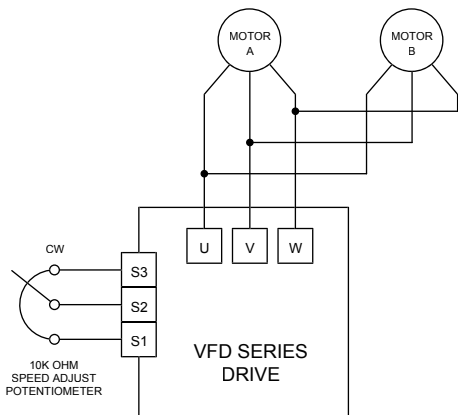

Figure 30. Single Speed Potentiometer Control of Multiple Motors

Quick Reversing

To reverse the direction of motor shaft rotation, install a DPDT center off switch as shown in Figure 31 below. The drive will stop the motor before reversing, so there is no need to wait for the motor to coast to a stop before changing direction. JMP506 must be set to brake. Refer to Figures 8 and 9 (pages 8 and 9) for Jumper Locations.

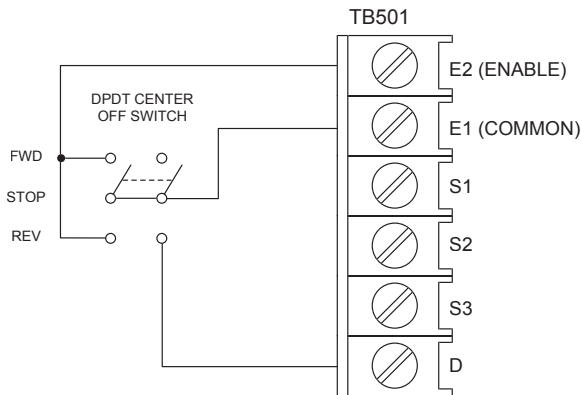

Figure 31. VFD Quick Reversing

Troubleshooting



Warning



Dangerous voltages exist on the drive when it is powered, and up to 60 seconds after power is removed and the motor stops. When possible, disconnect the voltage input from the drive while troubleshooting. **BE ALERT.** High voltages can cause serious or fatal injury.

Before troubleshooting

Perform the following steps before starting any procedure in this section:

- Disconnect AC voltage input from the drive. Wait 60 seconds for power to discharge. The green POWER LED will blink while power is discharging.
- Check the drive closely for damaged components.
- Check that no wire, chips, or other foreign material has become lodged on the printed circuit board.
- Verify that every connection is correct and in good condition.

- Verify that there are no short circuits or grounded connections.
- Check that the drive's rated phase current and RMS voltage are consistent with the motor ratings.

For additional assistance, contact your local Minarik distributor, or the factory direct by telephone at:

1-800-MINARIK (646-2745) or Fax: 1-800-394-6334

Diagnostic LEDs

Minarik VFD Series drives are equipped with diagnostic LED's to assist the user in troubleshooting and monitoring equipment status while in use. Refer to Figures 32 and 33 (page 52 and 53) for diagnostic LED locations.

POWER LED

The green POWER LED is on when AC line voltage is applied and the control's low-voltage power supply is operational.

ENABLE LED

The red ENABLE LED turns on whenever the inverter output is enabled.

FAULT LED

The red FAULT LED blinks on and off when the drive output is locked out or not ENABLED and any one of the following fault conditions occur:

1. Overvoltage
 - VFD 230AC controls: DC bus exceeds 400 VDC
2. Undervoltage
 - VFD 230AC controls: DC bus drops below 200 VDC
3. Instantaneous Overcurrent Trip - Inverter output current has exceeded safe levels (250%).

Note: The FAULT condition must be reset using the ENABLE function of the VFD (opening and closing the ENABLE input).

TORQUE (TQ) LIMIT LED

The yellow TQ LIMIT LED is on when the drive output current exceeds the threshold set by the TQ LIMIT trimpot. When the TQ LIMIT LED turns on, shut down the motor and drive by disabling or removing power. Check the motor to make sure it is not jammed or overloaded. The TQ LIMIT trimpot may need to be recalibrated. See the Calibration section (page 37) for information on calibrating the TQ LIMIT trimpot.

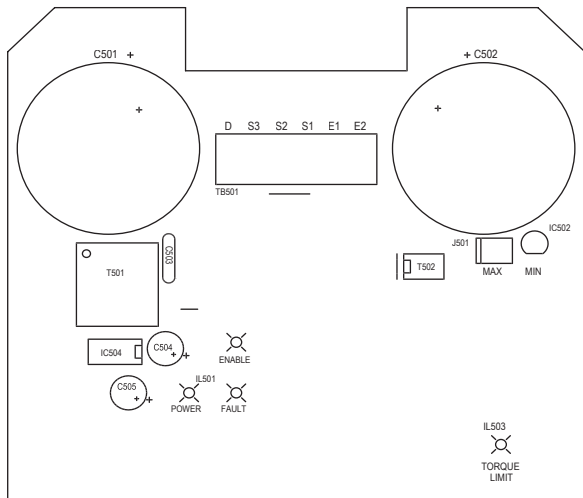

Figure 32. VFDA4X04 and VFDF4X04 LED locations

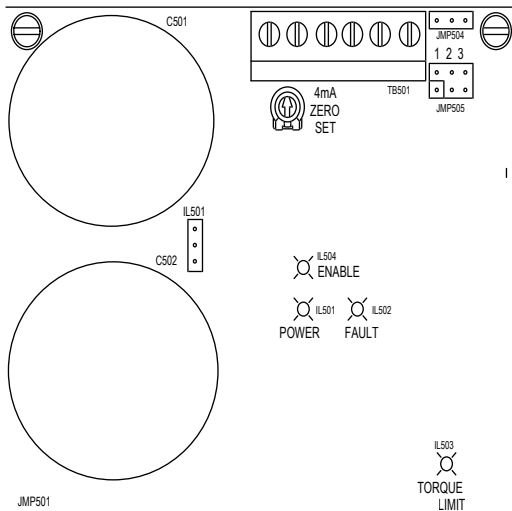

Figure 33. VFD05 and VFDP4X04 LED locations

Problem	Possible Cause	Suggested Solution
Internal line fuse blows	<ol style="list-style-type: none"><li data-bbox="397 268 666 323">1. Line fuses are the wrong size.<li data-bbox="397 418 666 473">2. Motor or motor cable is shorted to ground.<li data-bbox="397 536 666 711">3. Nuisance tripping caused by a combination of ambient conditions and high-current spikes (i.e. reversing).	<ol style="list-style-type: none"><li data-bbox="703 268 945 382">1. Check that line fuses are properly sized for the motor being used.<li data-bbox="703 418 945 501">2. Check motor cable and motor for shorts.<li data-bbox="703 536 945 681">3. Add a blower to cool the drive components; increase TQ LIMIT settings (page 41).
Internal line fuse does not blow, but the motor does not run	<ol style="list-style-type: none"><li data-bbox="397 773 666 888">1. Speed adjust potentiometer or voltage input signal is set to zero speed.<li data-bbox="397 951 666 1159">2. Speed adjust potentiometer or voltage input signal is not properly connected to drive input; connections are open.	<ol style="list-style-type: none"><li data-bbox="703 773 945 922">1. Increase the speed adjust potentiometer setting or voltage input signal.<li data-bbox="703 951 945 1067">2. Check connections to input. Verify that connections are not open.

Problem	Possible Cause	Suggested Solution
Internal line fuse does not blow, but the motor does not run (cont.)	<ol style="list-style-type: none"> 3. Drive is "tripped" off or has gone into thermal overload. 4. Drive has been disabled. 5. Drive is in current limit. 6. Drive is not receiving AC voltage input. 7. Motor is not connected. 	<ol style="list-style-type: none"> 3. Disable, then re-enable the drive. 4. Ensure that ENABLE (EN) and COM terminals are properly connected. 5. Verify that motor is not jammed. Increase TQLIM setting if it is set too low (page 41). 6. Apply AC line voltage to L1 and L2. 7. Connect motor to drive outputs U, V and W.
Motor runs too slow or too fast at set speed	<ol style="list-style-type: none"> 1. MAX SPD trimpot is not calibrated correctly. 	<ol style="list-style-type: none"> 1. Calibrate MAX SPD trimpot (page 40).

Problem	Possible Cause	Suggested Solution
Motor will not reach the desired speed	<ol style="list-style-type: none">1. MAX SPD setting is too low.2. Nominal input voltage may be too low for motor3. Motor is overloaded.	<ol style="list-style-type: none">1. Increase MAX SPD setting (page 41).2. Compare motor voltage to input voltage; replace motor if necessary3. Check motor load. Resize the motor or drive if necessary.
Motor pulsates or surges under load	<ol style="list-style-type: none">1. Motor “bouncing” in and out of torque limit.	<ol style="list-style-type: none">1. Make sure motor is not undersized for load; adjust TQ LIM setting CW (page 41).
Motor does not reverse	<ol style="list-style-type: none">1. Defective DIRECTION switch connection.2. Reversing circuit not working properly.3. Motor not wired correctly for reverse	<ol style="list-style-type: none">1. Check DIRECTION switch connection.2. Check reversing circuit by shorting TB501 (D) terminal to (E1) terminal with jumper wire.3. Check motor wiring Review motor connections section

Problem	Possible Cause	Suggested Solution
TQ is unsatisfactory at high speeds.	<ol style="list-style-type: none"><li data-bbox="397 268 664 290">1. TQ LIMIT set too low.<li data-bbox="397 359 653 413">2. Load may exceed rating of motor/drive.<li data-bbox="397 626 664 709">3. Nominal input voltage may be too low for motor.	<ol style="list-style-type: none"><li data-bbox="703 268 921 322">1. Check TQ LIM setting (page 41).<li data-bbox="703 359 938 593">2. "Fix" load (i.e., straighten mounting, coupling, etc.); or replace motor and drive with motor and drive rated for higher horsepower.<li data-bbox="703 626 938 742">3. Compare motor voltage to input voltage. Replace motor if necessary.

Optional Capacitor Kit (p/n: 202-0108)

In some applications, lowering carrier frequency reduces switching losses and increases bearing life in some motors. Minarik provides an optional capacitor kit for lowering the carrier frequency.

The default carrier frequency on VFD controls is 16kHz. Using one of the capacitors supplied in the kit, the carrier frequency can be lowered to a range of 12kHz to 4kHz.

Note: Audible noise will increase when the carrier frequency is lowered.

To lower the carrier frequency on all VFD controls, install one of the following 2-pin capacitors on the board:

LABEL ON CAPACITOR	FREQUENCY	VALUE
3n3J	12kHz	0.0033uF
6n8	10kHz	0.0068uF
10n	8kHz	0.01uF
33n	4kHz	0.033uF

See Figures 34 and 35 for Capacitor locations and installation instructions

Insert the 2-pins of the carrier frequency capacitor into the 2 socket holes (C503) located on board.

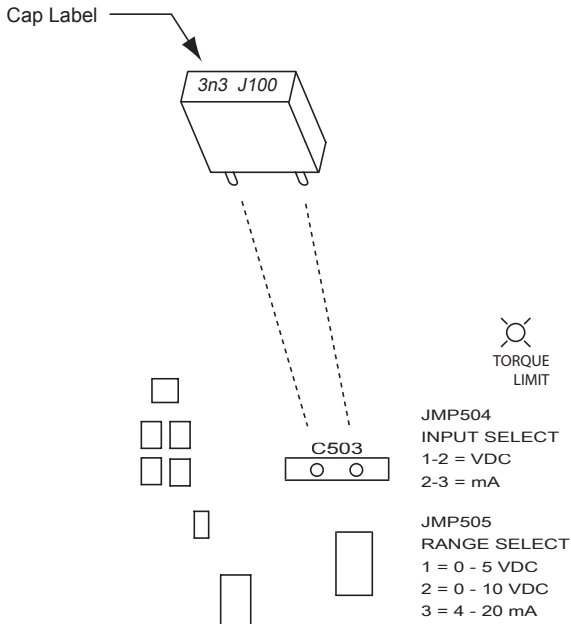

Figure 34. VFD05 and VFDP4X04 Carrier frequency capacitor location

Insert the 2-pins of the carrier frequency capacitor into the 2 socket holes (C507) located on board.

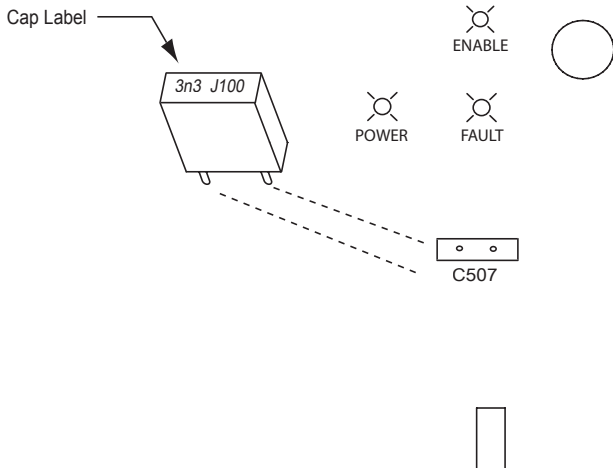

Figure 35. VFDA4X04 and VFDF4X04 Carrier frequency capacitor location

Replacement Parts

Replacement parts are available from Minarik Drives and its distributors for this drive series.

Table 2. Replacement Parts

Potentiometer Kit 202-0101	10K ohm, 5W Potentiometer 3/8-32 X 1/2 Nut 3/8IN Int. Tooth Lockwasher Pot Insulating Washer Non-insulated Female Connector 3 ea Insulated Female Connector
----------------------------	----------------------------------------------------------------------------------------------------------------------------------------------------------------------------

NOTES

NOTES

NOTES

Unconditional Warranty

A. Warranty

Minarik Drives warrants that its products will be free from defects in workmanship and material for twelve (12) months or 3,000 hours, whichever comes first, from date of manufacture thereof. Within this warranty period, Minarik Drives will repair or replace, at its sole discretion, such products that are returned to Minarik Drives, 14300 De La Tour Drive, South Beloit, IL 61080 USA.

This warranty applies only to standard catalog products, and does not apply to specials. Any returns for special controls will be evaluated on a case-by-case basis. Minarik Drives is not responsible for removal, installation, or any other incidental expenses incurred in shipping the product to and from the repair point.

B. Disclaimer

The provisions of Paragraph A are Minarik Drives sole obligation and exclude all other warranties of merchantability for use, express or implied. Minarik Drives further disclaims any responsibility whatsoever to the customer or to any other person for injury to the person or damage or loss of property of value caused by any product that has been subject to misuse, negligence, or accident, or misapplied or modified by unauthorized persons or improperly installed.

C. Limitations of Liability

In the event of any claim for breach of any of Minarik Drives obligations, whether express or implied, and particularly of any other claim or breach of warranty contained in Paragraph A, or of any other warranties, express or implied, or claim of liability that might, despite Paragraph B, be decided against Minarik Drives by lawful authority, Minarik Drives shall under no circumstances be liable for any consequential damages, losses, or expense arising in connection with the use of, or inability to use, Minarik Drives product for any purpose whatsoever.

An adjustment made under warranty does not void the warranty, nor does it imply an extension of the original 12-month warranty period. Products serviced and/or parts replaced on a no-charge basis during the warranty period carry the unexpired portion of the original warranty only.

If for any reason any of the foregoing provisions shall be ineffective, Minarik Drives liability for damages arising out of its manufacture or sale of equipment, or use thereof, whether such liability is based on warranty, contract, negligence, strict liability in tort, or otherwise, shall not in any event exceed the full purchase price of such equipment.

Any action against Minarik Drives based upon any liability or obligation arising hereunder or under any law applicable to the sale of equipment or the use thereof, must be commenced within one year after the cause of such action arises.



MINARIK DRIVES

14300 De La Tour Drive

South Beloit, IL 61080

Phone: (800) MINARIK or (815) 624-5959

Fax: (815) 624-6960

www.minarikdrives.com

Document number 250-0381, Revision 01

Printed in the U.S.A – 12/04